



OSIsoft®
REGIONAL
SEMINARS 2012
The **Power** of **Data**

“Data is your only weapon for improved performance.”

Dr. Don Paul, Vice President CTO, Chevron

Who Uses the PI System?

- Renewable Energy Dispatch Operator
- Control Room Operator
- Operations Supervisor
- Operations Lead
- Transmission Dispatcher
- System Dispatch
- Pipeline Controller
- Planning/Reliability Engineer
- SCADA Engineer
- Power Operations Engineer
- Automation Engineer
- Project Engineer
- Control Systems Engineer
- Process Engineer
- Process Control Engineer
- Commercial Engineer
- MES/PIMS Engineer
- Technical Service Engineer
- PI System Engineer
- Real Time Systems Engineer
- Instrument and Control Engineer
- Gas Engineer
- Performance Engineer
- Operations Engineer
- Systems Engineer
- Electrical Engineer
- Utility Engineer
- Power Systems Engineer
- Reconciliation Engineer
- Reservoir Engineer
- Reliability Engineer
- Generation Engineer
- Plant Engineer
- Bioprocess Equipment Engineer
- Mechanical Engineer
- Domain Expert Engineering
- EMS Engineer
- Automation MES Engineer
- Process Development Engineer

More PI System Users

- PI Application Engineer
- Sr. Manager, O&M IT Applications
- IT Manager - Mill Applications
- Refining I.T. Manager
- Data Systems Administrator
- Application Support Analyst
- Manufacturing IT Architect
- Data Systems Analyst
- Director of Application Development
- Tech Support for Operations
- IT Director, Consumer Packaging
- Global PI - Business Solutions Architect
- Process Systems Application Engineer
- IT Business Partner
- Applications Support Lead
- Director, Sustainable IT
- Information Security Engineer
- Product Line Manager
- Control System Supervisor
- System performance manager
- DCS Supervisor
- IT Applications Manager
- Plant Manager
- Maintenance Manager
- Global Production Volumes Manager
- PI System Manager
- Development Manager
- Maintenance Team Leader
- Product Engineering Mgr
- IT Operations Manager
- Managing Director
- Operations Manager
- Business Development Manager
- Central Heating & Cooling Plant Manager
- Global Production Services Manager
- Director, Midstream Operations North
- Director, Smart Network Operations
- IT - Director
- Hydro Generation Supervisor
- Manager, Data Analytics
- Infrastructure Manager
- Manufacturing Process Information Manager
- Program Manager

And the list goes on...

- Market sales Manager Utilities
- EMS Supervisor
- Asset Management Program
- Mine Superintendent
- Division Manager
- Business Development Manager
- Supply Operations Supt.
- Program Manager, Pipeline & Power Industrial Control & Operating Environment
- Supervisor, EMS SCADA Systems
- Mgr, Plant I.T.
- Manager, Process Control & EIT Program, XPS
- Plant Optimization & NERC CIP Compliance Manager
- Process Controls Software Manager
- Director of Platform Product Management
- Electrical & Control Systems Manager
- Business Relationship Manager
- Control Syst. Suprv.
- Technical Services Supervisor
- Scada & Process Control Supervisor
- Maintenance Supervisor Process control/IT
- Financial Systems Analyst
- Reliability Analyst
- Principal Operations Systems Analyst
- Business Systems Analyst
- Senior Sustainability Advisor
- Business Analyst
- Energy Systems Analyst
- Performance Analysis
- Real-Time Analyst
- Senior Sourcing Analyst
- Analyst Industrial IT
- IT Analyst
- Energy Analyst
- Engineering Analyst
- Wind Resource Data Analyst
- Hydro Analyst
- Quality Analyst
- EMS Analyst
- Process Systems Analyst
- Mill Application Analyst
- Process Computing Analyst
- Operations Analyst

Typical Users of the PI System

- Operators
- Supervisors
- Process Engineers
- Maintenance

How Does PI System Data Help?

- Provide current status outside of control room
- Allow Situational Awareness for quick decision-making
- Support troubleshooting operations problems
- Measure effectiveness over time
- Compare performance
- Monitor equipment health
- Measure quality

RockTenn

- Needed to bring Users together
 - Interesting use cases emerging from mills
 - Corporate provided some ideas but Mills were interested in developing their own
- PI System Power User Group
 - Build cross Mill relationships
 - Promote idea sharing
 - Friendly competition promotes learning and initiative

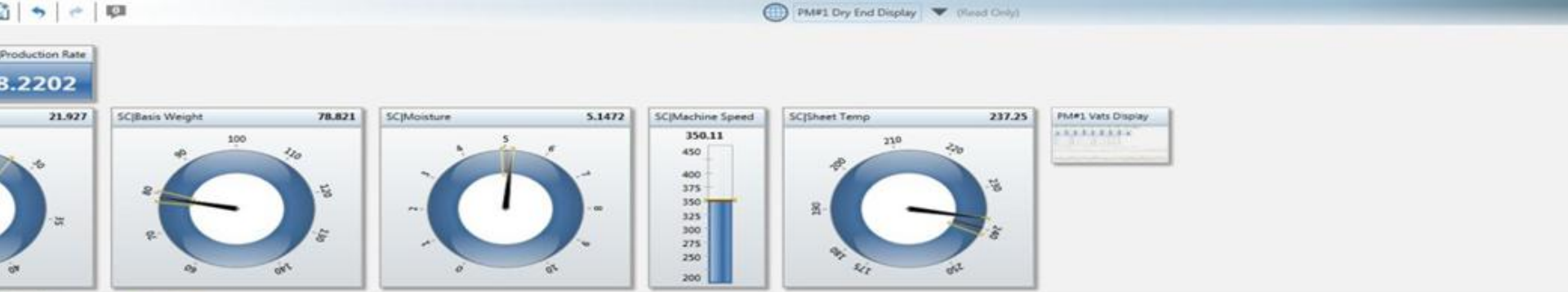

SC[Basis Weight] 78.821 Bb/1000 R^2 | SC[Moisture] 5.1472 %



“Operators are afraid of full blown PC Applications, PI Coresight will give them easy to use Ad hoc capabilities” – Matt Corcoran

Description	Value	Trend	Average	StdDev	Maximum	Minimum
PM1 Caliper Reel: 2 Sig	1.051		0.80739	0.073061	1.051	0.73772
PM2 Basis Weight Reel: 2 Sig	4.7333		3.8935	0.45412	4.8964	2.8524
PM1 Moisture Reel: 2 Sig	0.4564		0.43212	0.025518	0.4564	0.408

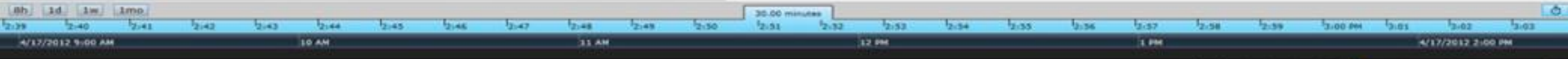

RockTenn Water Bill in Excel

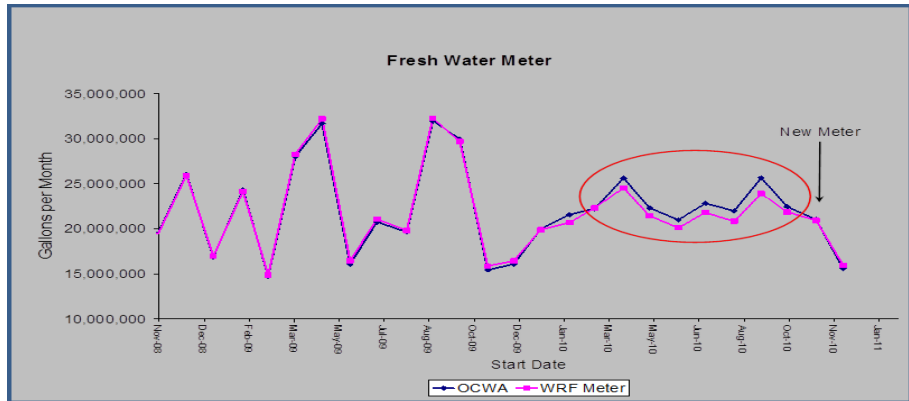

- Real time water usage stored in the PI System and analyzed in Excel using PI DataLink
- Found a faulty water meter installed by Utility company
- Overcharging for Effluent treatment due to a build up on the Effluent meter

RockTenn Waste Control

- Slab calculator helps operators calculate what they trim to reduce waste
- Operators assign reason codes and comments

	A	B	C	D	E	F	G
1	PIServer	NT327002	3270				Ready
2	PaperMachine	PM1					
3	StartTime	3/12/2012 7:00	Get Data				
4	EndTime	3/19/2012 7:00					
6		Loss (Feet)	161,099			4.45%	% Total Loss
7	Total	AS400 Lineal Feet	3,457,307			2.07%	% Unaccounted for Loss
8	Total	PI Reel Lineal Feet	3,618,406	193	86,194	74,905	Unaccounted for Loss
9							
	ID	Start Time	Reel #	Min	Slab	Cause	Comments
11		13-Mar-12 16:35	RT512C1304	14.9	7,576	Grade Change	.020unc - .018 mill
12		13-Mar-12 21:07	RT512C1312	4.4	2,309	Other	cut 1.5" clayoff / cut 5" off e roll c.s.
13		13-Mar-12 21:44	RT512C1313	5.4	2,832	Coating AK	clayoff c.s.
14		14-Mar-12 00:14	RT512C1317	1.8	952	Hole	holes
15		14-Mar-12 02:02	RT512C1320	0.0	0	Coating AK	set 1 b.r. clayoff c.s.
16		14-Mar-12 02:52	RT512C1321	7.0	3,683	Coating AK	clayoff c.s.
17		14-Mar-12 03:45	RT512C1322	7.3	3,843	Other	cleaning backing roll and scraping oven roll
18		14-Mar-12 04:28	RT512C1323	7.5	3,931	Caliper Change	.018-.016
19		14-Mar-12 05:03	RT512C1324	0.0	0	Caliper Change	no set

RockTenn Equipment Run Time

PI ProcessBook - [BR Basket, Rotor and Plate Days.PDI]

Boxboard Stock Prep - Extraction Plate, Rotor & Screen Basket Run Days

Microsoft Excel - BR Equipment Run Times.xls

Equipment	Target Days	Actual Days	Change Date	Comment	Next Change Assuming Continuous Operation
Filler Pulper Extraction Plate	270	272	4/21/2010	Date updated by JBrahs	1/30/2011
Filler Pulper Rotor Time	270	272	4/21/2010	Date updated by JBrahs	1/30/2011
Turbo Extraction Plate Time	135	25	1/7/2011	Holes in extraction plate, shut down to change	5/22/2011
Turbo Rotor Time	135	25	1/7/2011	Date updated by jbrahs	5/22/2011
Filler North Primary Screen Basket Time	360	4	2/24/2010	From the Secondary	1/22/2012
Filler South Primary Screen Basket Time	360	24	1/6/2011	Date updated by jbrahs	1/2/2012
Filler Secondary Screen Basket Time	360	189	6/15/2010	Date updated by nlarson	7/21/2011
Filler Tertiary Screen Basket Time	270	85	11/3/2010	Date updated by nlarson	8/5/2011
Liner Pulper Extraction Plate Time	360	114	10/5/2010	Date updated by jbrahs	10/5/2011
Liner Pulper Rotor Time	360	114	10/5/2010	Date updated by jbrahs	10/5/2011
Liner Barrier Screen Basket Time	360	187	7/20/2010	Date updated by jbrahs	7/23/2011
Liner Primary Screen Basket Time	360	272	4/26/2010	Date updated by jbrahs	4/30/2011
Liner Secondary Screen Basket Time	360	318	3/10/2010	Date updated by JBrahs	3/15/2011
Hydrapurge Extraction Plate Time	180	90	10/29/2010	Date updated by jbrahs	5/1/2011
Hydrapurge Rotor Time	180	90	10/29/2010	Date updated by jbrahs	5/1/2011

Glatfelter Paper Lab Technician

- Contest where multiple unique user-created projects were aimed at making the job easier, improving product quality, tracking costs and saving money
- Wants to see status of operations without leaving the lab
- Built his own display that checks additives and other key properties

#7 Paper Machine Overview

ABB Head Position: 232 inches

Grade Code: ██████████
 BW: ██████████ #/Rm
 Deckle: 171.86"
 Wire Speed: 2083 FPM
 Reel Speed: 2155 FPM
 Moisture: ██████████ %
 ASH: ██████████ %



Couch Vac: ██████████ In Hg 
 Stock Flow: ██████████ GPM 
 Main: ██████████ PSI 
 A/S: ██████████ PSI 

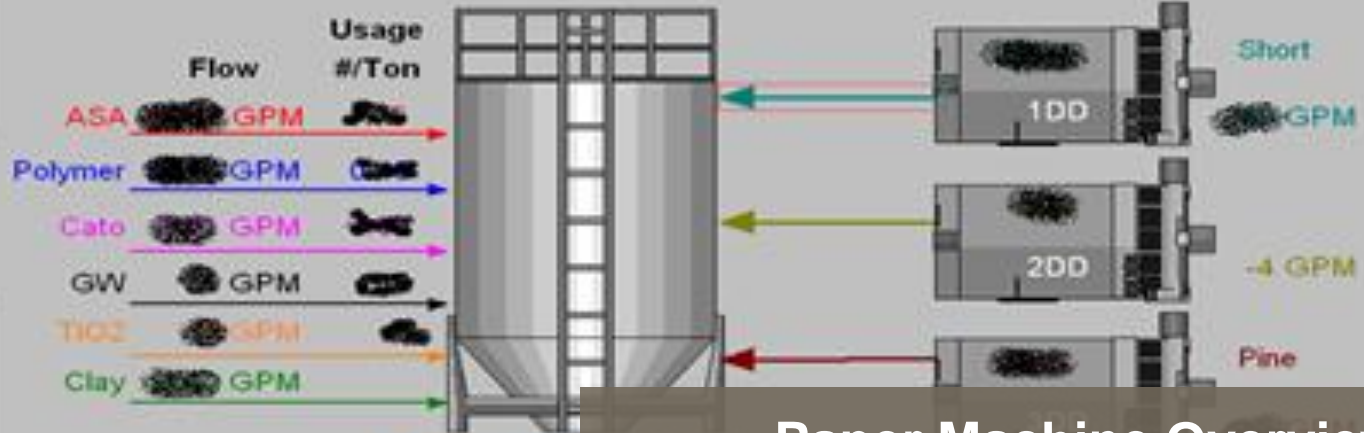

Sheet Status



Sizing

Starch: ██████████ GPM
 Water: ██████████ GPM
 Clay / Starch: ██████████
 Oil flow: ██████████ GPM



Broke Chest #1: 7.67 FT
 Broke Chest #2: -0 FT



Broke Cons: ██████████
 Short Cons: ██████████
 Pine Cons: ██████████
 T.S. Cons: 4 ██████████ %
 Couch Cons: 3 ██████████ %



Paper Machine Overview
Glatfelter

Coated Broke flow: ██████████ GPM
 Uncoated broke flow: ██████████ GPM



Amonix Remote Asset Monitoring

- Needed to monitor performance of remote equipment, starting with nothing
- Wanted an easy, low cost data system
 - Low Cost of maintenance
 - Easy to maintain from Remote (unmanned) locations
 - Full end-to-end system

Amonix Field monitoring

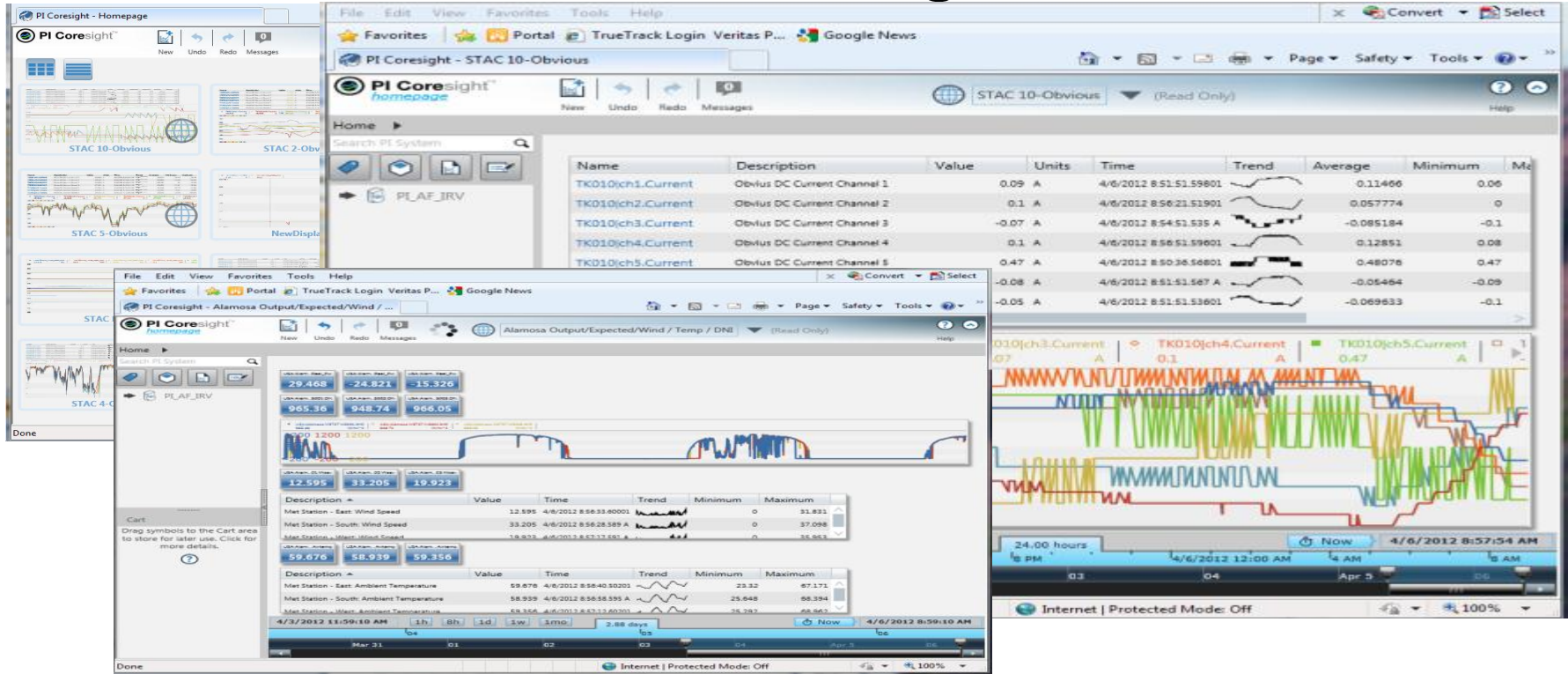

Amonix Standard Reporting

- Engineers
- Project Managers

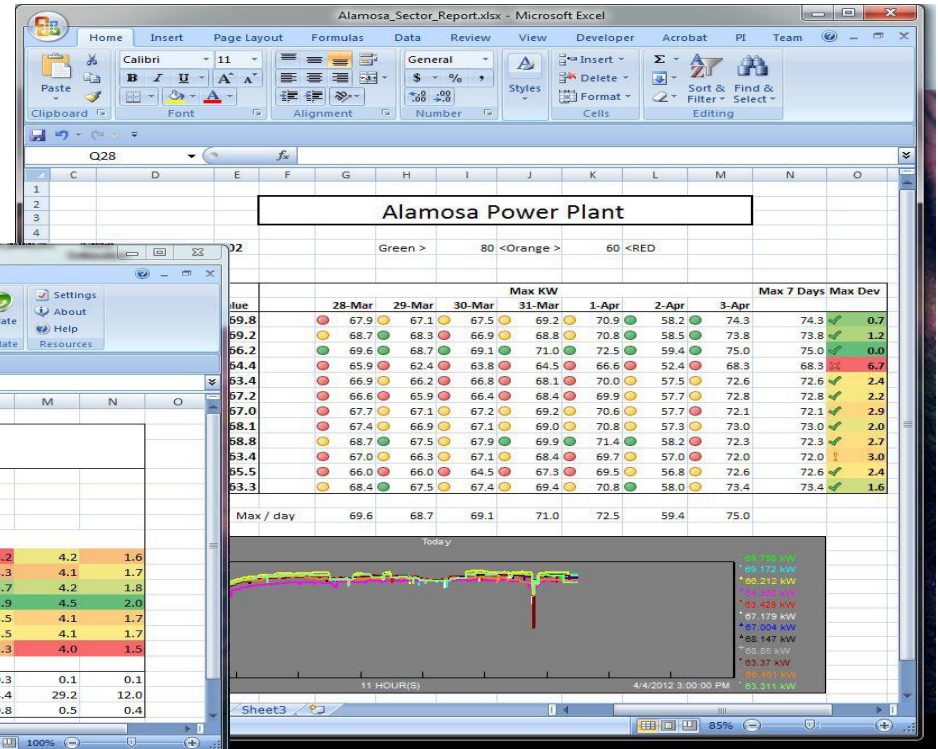
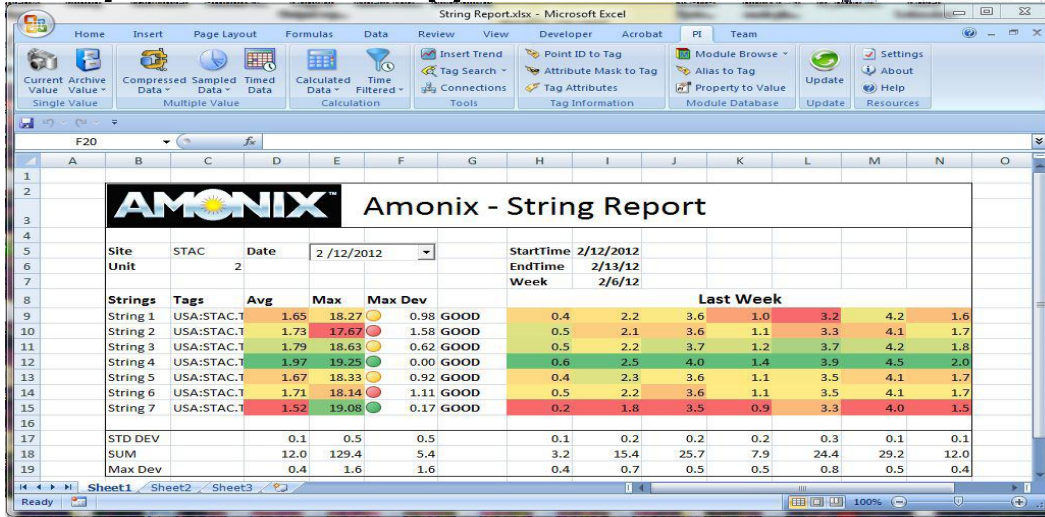

Amonix Expertise

- New to the PI System
- No formal training
- Made use of YouTube learning channel

Other Audiences for PI Data

- Executives

- CFO
- CEO
- President
- Chief Sustainability Officer
- Vice President
- Director
- Chief Technical Officer
- VP Field Operations
- VP, Marketing
- CIO Manufacturing
- Vice President Product Development
- Vice President of Sales
- Chairman
- VP of Operations and COO
- Board Member
- Vice President of Technical Services
- Vice President Global Sales and Marketing
- Vice President of Engineering
- Vice President, Marketing
- Vice President Condition Monitoring
- Vice President Corporate Communications
- Vice President of Marketing & Business Dev.
- Vice President Predictive Equipment Health Management
- Vice President Program Management
- Vice President - Global Strategies and Solutions
- Vice President, Operations and Business Development
- Executive in Information Management for Production Operation

- Business Analysts

- Customers

- Public

- Contractors

- Vendors

Some Atypical Uses of the PI System

- Feeding into cost/profit - Alcoa Demand Response
- Sustainability initiatives – Seattle Mariners facility management
- Reducing energy use across businesses in Vermont – IBM
- Monitoring a computing infrastructure – Weill Cornell
- Managing Critical Facilities – Harvard Medical School
- Sharing Utility Data – Northeast Utilities

Alcoa Power Markets Coordinator

- Wanted to balance plant power needs against ability to generate revenue from local ISO
- Must coordinate both demand and capability
- Needs real time data to work

Alcoa Demand Response Data

Warrick Demand Response

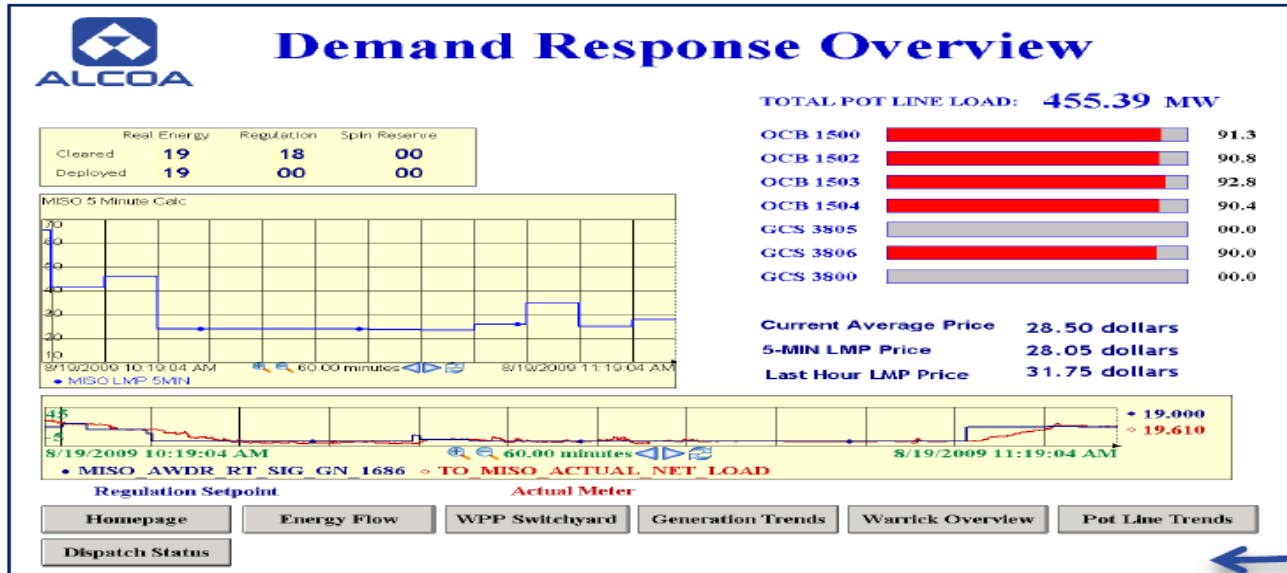

Real Time
Data

Customer
Driven

Hyperlinks

Communicating with Alcoa Operations

Power Plant Operating Tools

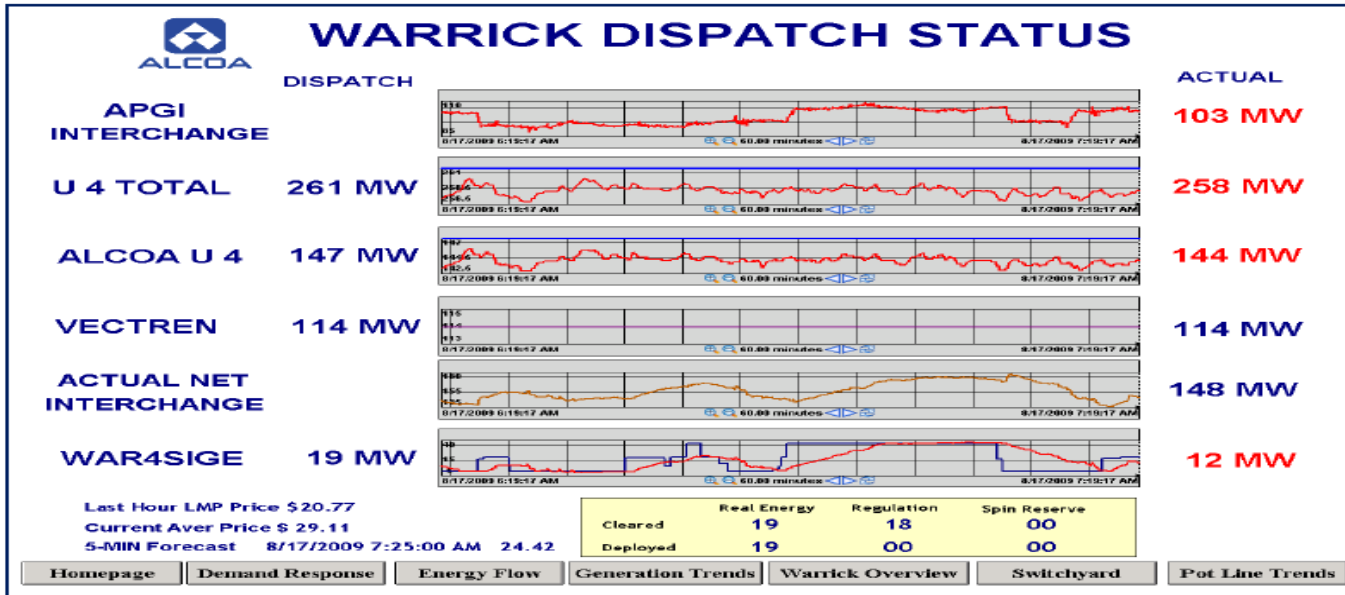

Functionality

Operator Buy-in

Ownership



Facility Operations

- Vice President of Ballpark Operations
- Wanted to reduce the amount of waste (recycling) and utility use (power, water)
- Data and competition (with other similar facilities) driving change
- PI System data shows him when the roof is opened, when there is a lot of kitchen exhaust, the difference made by changing parking garage lighting...

Stadium Sustainability

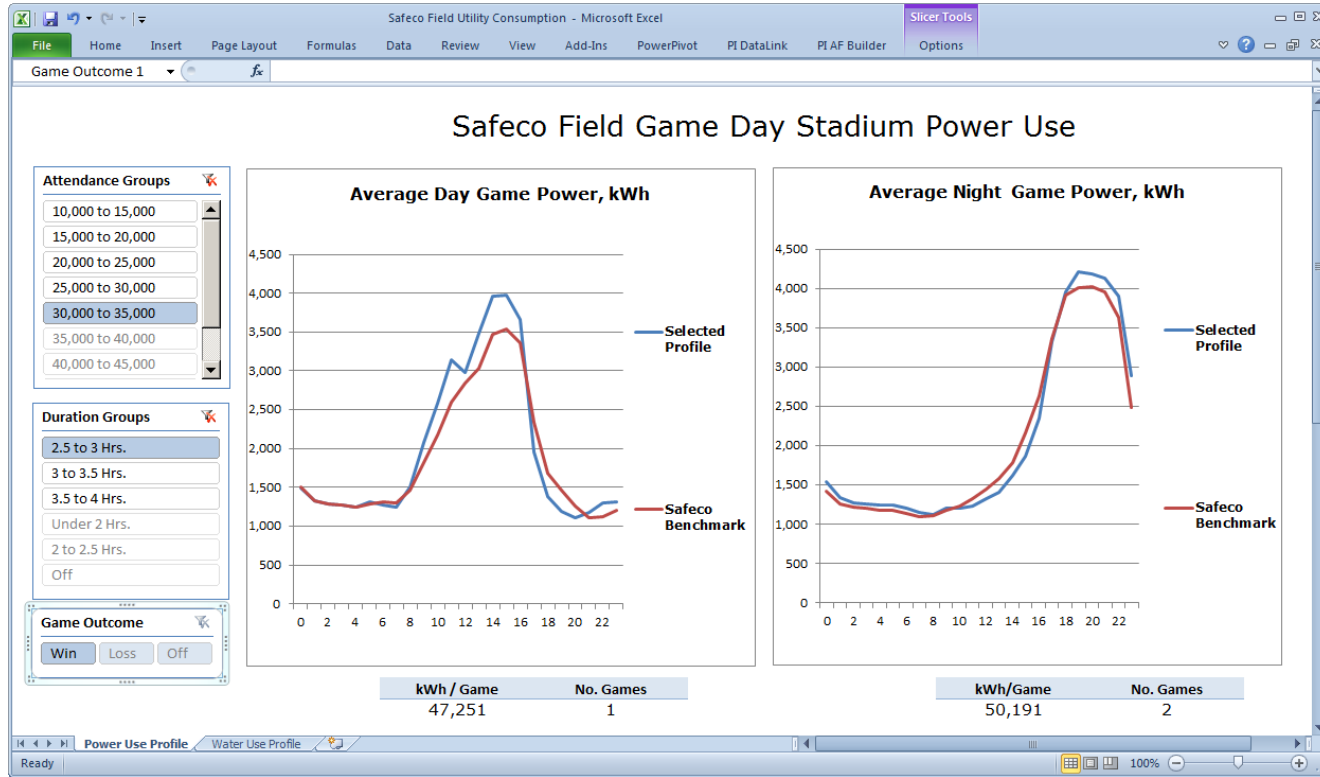

Stadium Sustainability

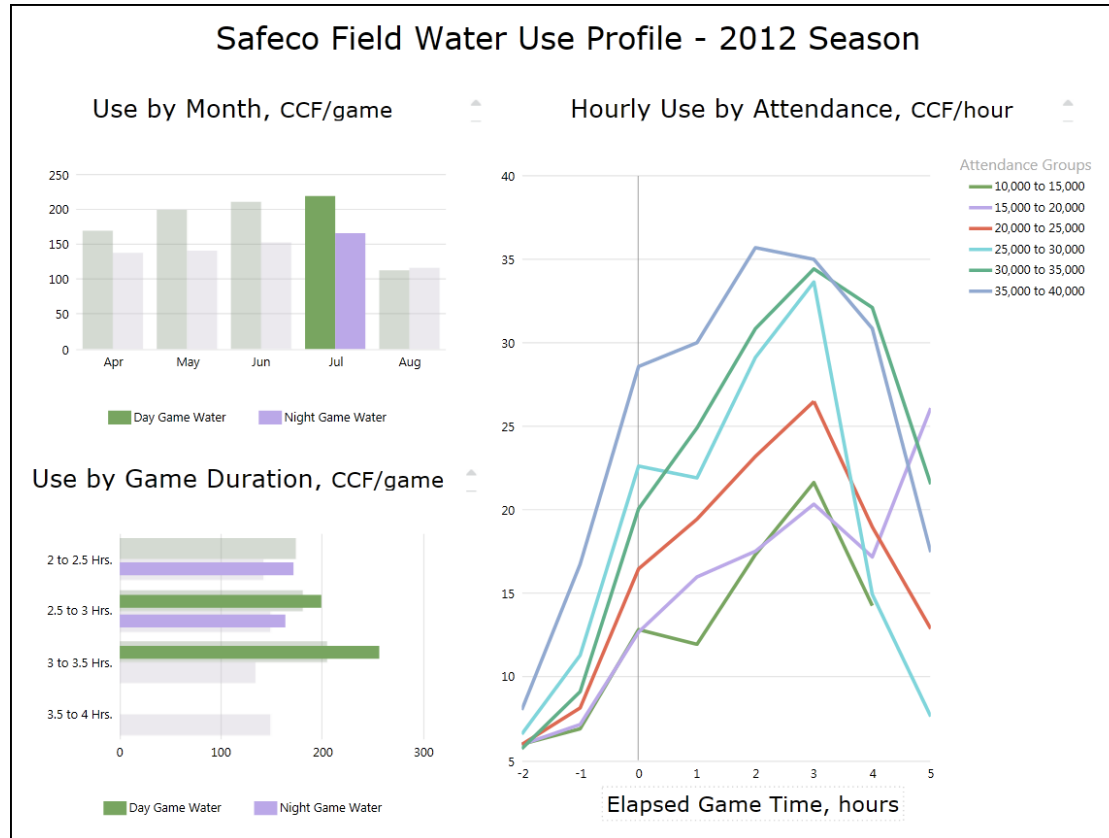

Ballpark Operations

- Making data available to Engineers, Security, and Control Room Operators allows them to gauge current performance
- Seeing results drives process improvement
- Must be easy to get to
- Seeing performance data allows them to adjust operations to improve over time

Facility Monitoring

Utility Dashboard

- Real time information
- Automated event reports
- Share and compare with MLB



Vermont Businesses

- Collaboration among businesses in Vermont to reduce power use
- Part of smart grid initiative
- Sharing data across business entities
- Data viewed by business analysts, facility operators and administrators to affect usage patterns by reducing system demands, improving efficiency and providing a financial return
- Sharing best practices within a community

Business Collaboration

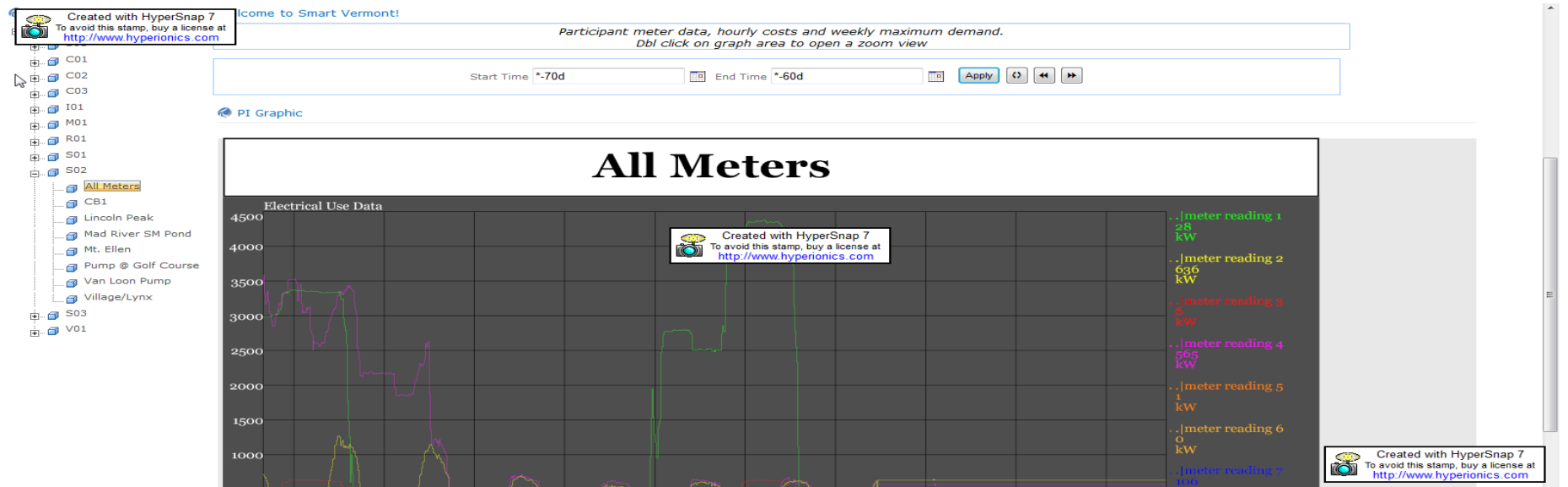

Weill Cornell Medical College

- High power computers used for research
- Needed to monitor and publish availability
- Wanted to conserve power used by compute clusters



OF
PHYSIOLOGY
AND
BIOPHYSICS

Public kiosk showing
computing status

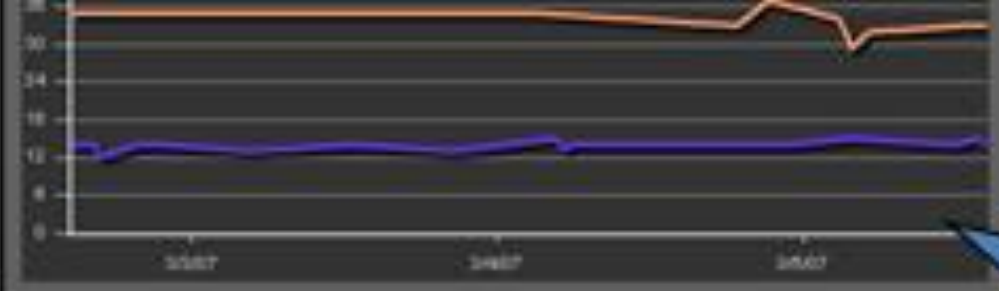

Note correlation between temperature and cluster usage



Cluster Power Mgmt



Powered down



Many more
stories on
the OSIsoft
web site

Providing Data for Your Users

- Some users need data they can work with to investigate
- Some users need to see previous data
- Some users just need to see current data

PI WebParts

- You have a SharePoint environment and want to make use of its support by IT
- Your users need to see a collection of information from different sources, including the PI System
- Your users don't want to build new displays
- You want to provide navigation that guides different audiences to the content they need

Report Type

Region

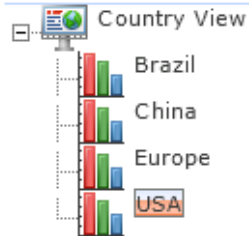

PI TimeRange

Start Time *-2h End Time * Apply ↺ ⏪ ⏩

Real Time KPIs

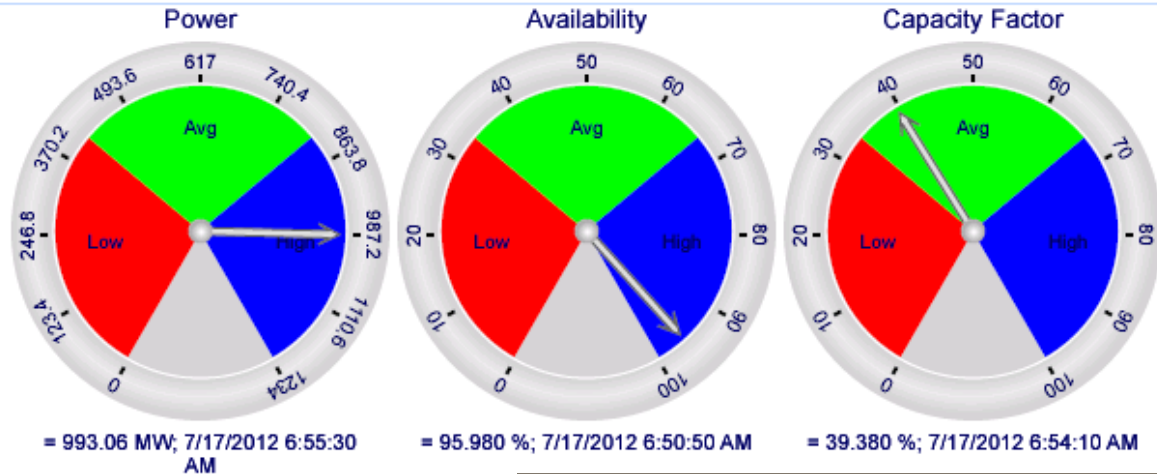

Economical Data

Dataset	Time	Value	EngineeringUnits
Energy Price per MWh	7/17/2012 6:58:00 AM		769 USD
Daily Revenue	7/17/2012 6:50:10 AM		0.15746 MUSD
Running Turbines	7/17/2012 6:51:00 AM		789 Unit(s)
Yearly Revenue	7/17/2012 6:50:20 AM		396.16 MUSD

PI WebParts dashboard

PI Coresight

- Your users need to explore data quickly or look at quick displays built by others
- Your users don't want to install anything
- You have no SharePoint environment



PLEASE
PAUSE
FOR
DEMO

PI DataLink

- Your users expect to work with numbers
- Your users want to build their own reports
- Your users are comfortable with Excel
- Your users want Excel charts

	A	B	C	D	E	F	G	H	I
1	Grand Ridge Wind Farm								
2	Black Wolf Wind Farm	56.7	%						
3	Deep Valley Wind Farm								
4	Eldorado Wind Farm								
5	Grand Ridge Wind Farm	2488.19	\$						
6	White Bear Wind Farm	212696.12	\$						
7	Wild River Wind Farm								
8	Windy Valley Wind Farm								
9	Yellow Creek Wind Farm								
10	Installed Capacity:	9000	kW						
11	Instant Power:	858	kW						
12	Exp.Capacity Factor:	38	kW						
13	Actual Factor:	9.53	kW						
14	MTD Generation:	399804.73	kWh						
15	Daily Generation:	4677.04	kWh						
16									
17									
18									
19									
20									
21									
22									
23									
24									
25									

Unit Summary		
Turbines In Production	Faulted	Average
6	0	56.7

	Current	Previous Month	YTD	Plan
Average Capacity Factor (%)	9.1	34.0	240.0	38.0
Average Generation (MWh)	399804.7	2.2	9.2	29.4
Operating Efficiency (%)	114.2	102.8	105.1	98.0
Number of Employees	4	5	N/A	7
Regulation Non-Compliance	1	1	2	2

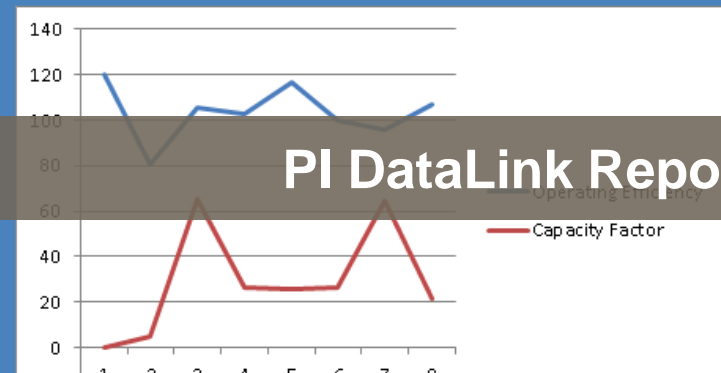

PI DataLink Report

PI ProcessBook

- Your users want to build their own graphical displays
 - Or
 - You have a group that builds displays for others
- Your users need to monitor how the process is progressing
- Your users need customized behavior or layout

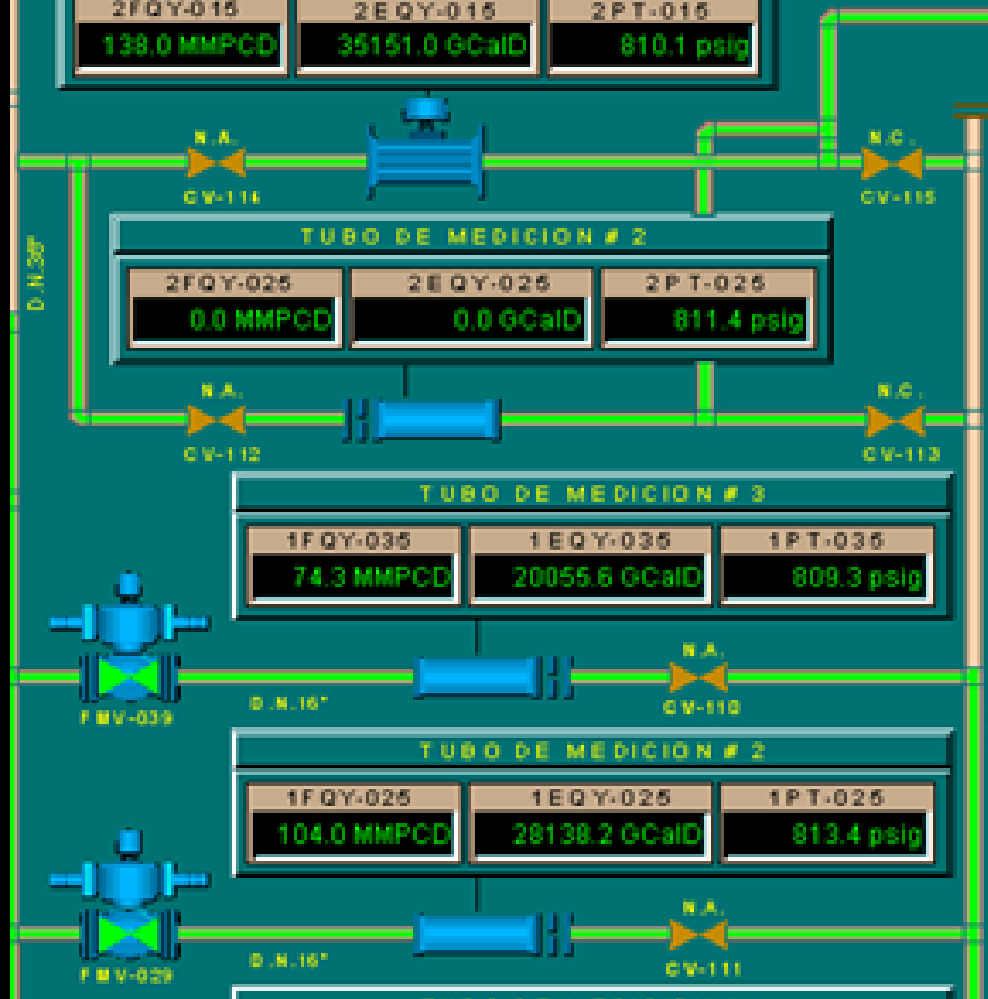

Pipelines-Emergency Systems
 PEMEX
 2009 - User Conference - San Francisco

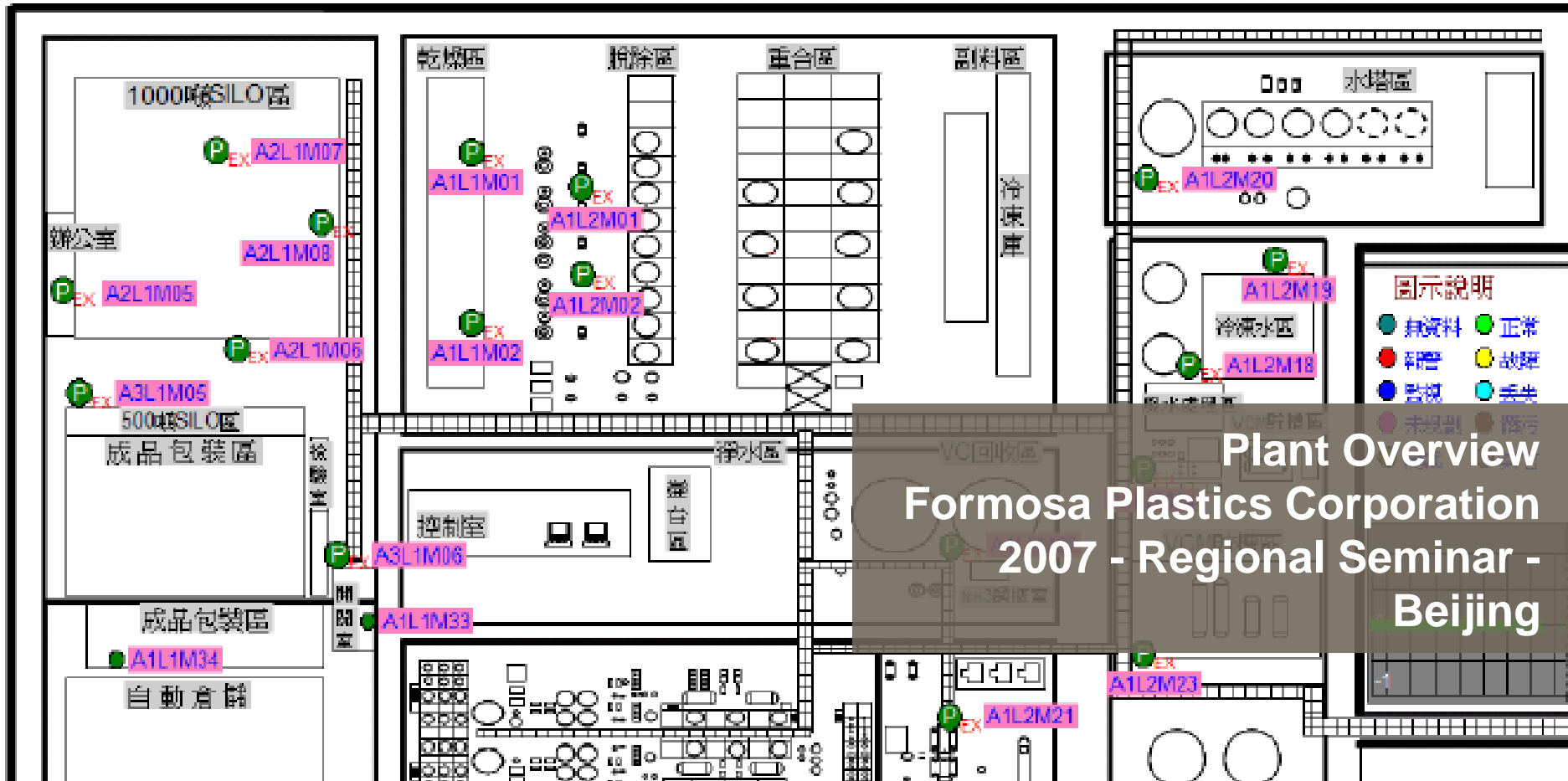

Plant Overview
Formosa Plastics Corporation
2007 - Regional Seminar -
Beijing

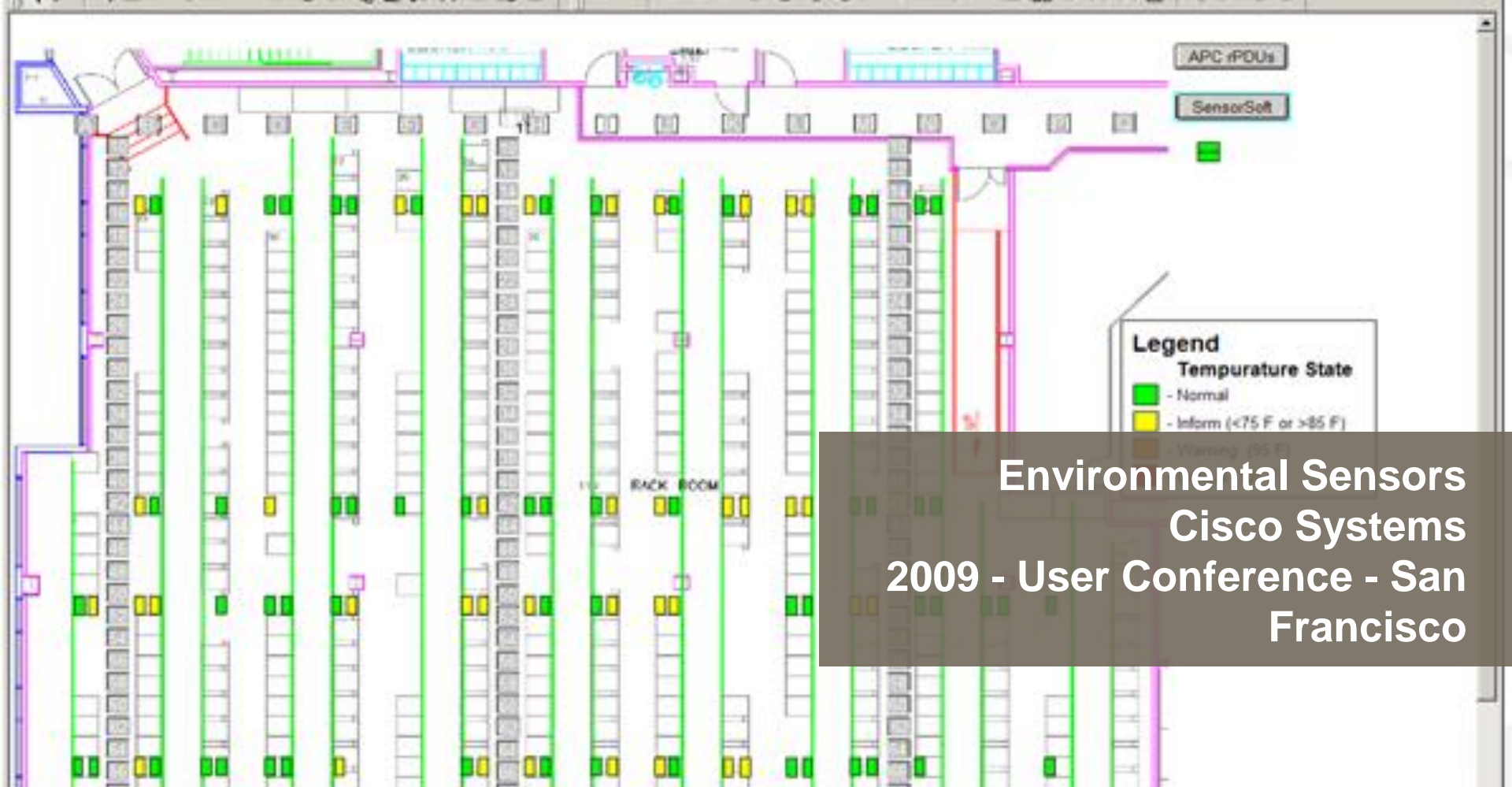

**Environmental Sensors
Cisco Systems
2009 - User Conference - San
Francisco**

Who Should Be Using PI System Data?

- Renewable Energy Dispatch Operator
- Control Room Operator
- Operations Supervisor
- Operations Lead
- Transmission Dispatcher
- System Dispatch
- Pipeline Controller
- Planning/Reliability Engineer
- SCADA Engineer
- Power Operations Engineer
- Automation Engineer
- Project Engineer
- Control Systems Engineer
- Process Engineer
- Process Control Engineer
- Commercial Engineer
- MES/PIMS Engineer
- Technical Service Engineer
- PI System Engineer
- Real Time Systems Engineer
- Instrument and Control Engineer

- Market sales Manager Utilities
- EMS Supervisor
- Asset Management Program
- Mine Superintendent
- Division Manager
- Business Development Manager
- Supply Operations Supt.
- Program Manager, Pipeline & Power Industrial Control & Operating Environment
- Supervisor, EMS SCADA Systems
- Mgr, Plant I.T.
- Manager, Process Control & EIT Program, XPS
- Plant Optimization & NERC CIP Compliance Manager
- Process Controls Software Manager
- Director of Platform Product Management
- Electrical & Control Systems Manager
- Business Relationship Manager
- Control Syst. Suprv.
- Technical Services Supervisor
- Scale & Process Control Supervisor
- Maintenance Supervisor Process control/IT

- Gas Engineer
- Performance Engineer
- Operations Engineer
- Systems Engineer
- Electrical Engineer
- Utility Engineer
- Power Systems Engineer
- Reconciliation Engineer
- Reservoir Engineer
- Reliability Engineer
- Generation Engineer
- Plant Engineer
- Bioprocess Equipment Engineer
- Mechanical Engineer
- Domain Expert Engineering
- EMS Engineer
- Automation MES Engineer
- Process Development Engineer

- Financial Systems Analyst
- Reliability Analyst
- Principal Operations Systems Analyst
- Business Systems Analyst
- Senior Sustainability Advisor
- Business Analyst
- Energy Systems Analyst
- Performance Analyst
- Real-Time Analyst
- Senior Sourcing Analyst
- Analyst Industrial IT
- IT Analyst
- Energy Analyst
- Engineering Analyst
- Wind Resource Data Analyst
- Hydro Analyst
- Quality Analyst
- EMS Analyst
- Process Systems Analyst
- Mill Application Analyst
- Process Computing Analyst
- Operations Analyst

- PI Application Engineer
- Sr. Manager, O&M IT Applications
- IT Manager - Mill Applications
- Refining I.T. Manager
- Data Systems Administrator
- Application Support Analyst
- Manufacturing IT Architect
- Data Systems Analyst
- Director of Application Development
- Tech Support for Operations
- IT Director, Consumer Packaging
- Global PI - Business Solutions Architect
- Process Systems Application Engineer
- IT Business Partner
- Applications Support Lead
- Director, Sustainable IT
- Information Security Engineer
- Product Line Manager
- Control System Supervisor
- System performance manager
- DCS Supervisor

• Executives

- CEO
- CFO
- President
- Chief Sustainability Officer
- Vice President
- Director
- Chief Technical Officer
- VP Plant Operations
- VP Marketing
- CIO Manufacturing
- Vice President Product Development
- Vice President of Sales
- Chairman
- VP of Operations and COO
- Sales Director
- Vice President of Technical Services
- Vice President Client Sales and Marketing
- Vice President of Engineering
- Vice President, Strategy
- Vice President Contract Marketing
- Vice President Corporate Communications
- Vice President of Marketing & Business Dev.
- Vice President Facilities Equipment Health Management
- Vice President Program Management
- Vice President - Client Strategy and Solutions
- Vice President, Operations and Business Development
- Executive in Information Management /or Production Operator

- IT Applications Manager
- Plant Manager
- Maintenance Manager
- Global Production Volumes Manager
- PI System Manager
- Development Manager
- Maintenance Team Leader
- Product Engineering Mgr
- IT Operations Manager
- Managing Director
- Operations Manager
- Business Development Manager
- Central Heating & Cooling Plant Manager
- Global Production Services Manager
- Director, Midstream Operations North
- Director, Smart Network Operations
- IT - Director
- Hydro Generation Supervisor
- Manager, Data Analytics
- Infrastructure Manager
- Manufacturing Process Information Manager
- Program Manager

• Business Analysts

- Customers
- Public
- Contractors
- Vendors



What's Next?



PI System Data Everywhere

- Cloud options for sharing data
- Support for PI System displays on a variety of devices

PI Coresight with Mobile Clients

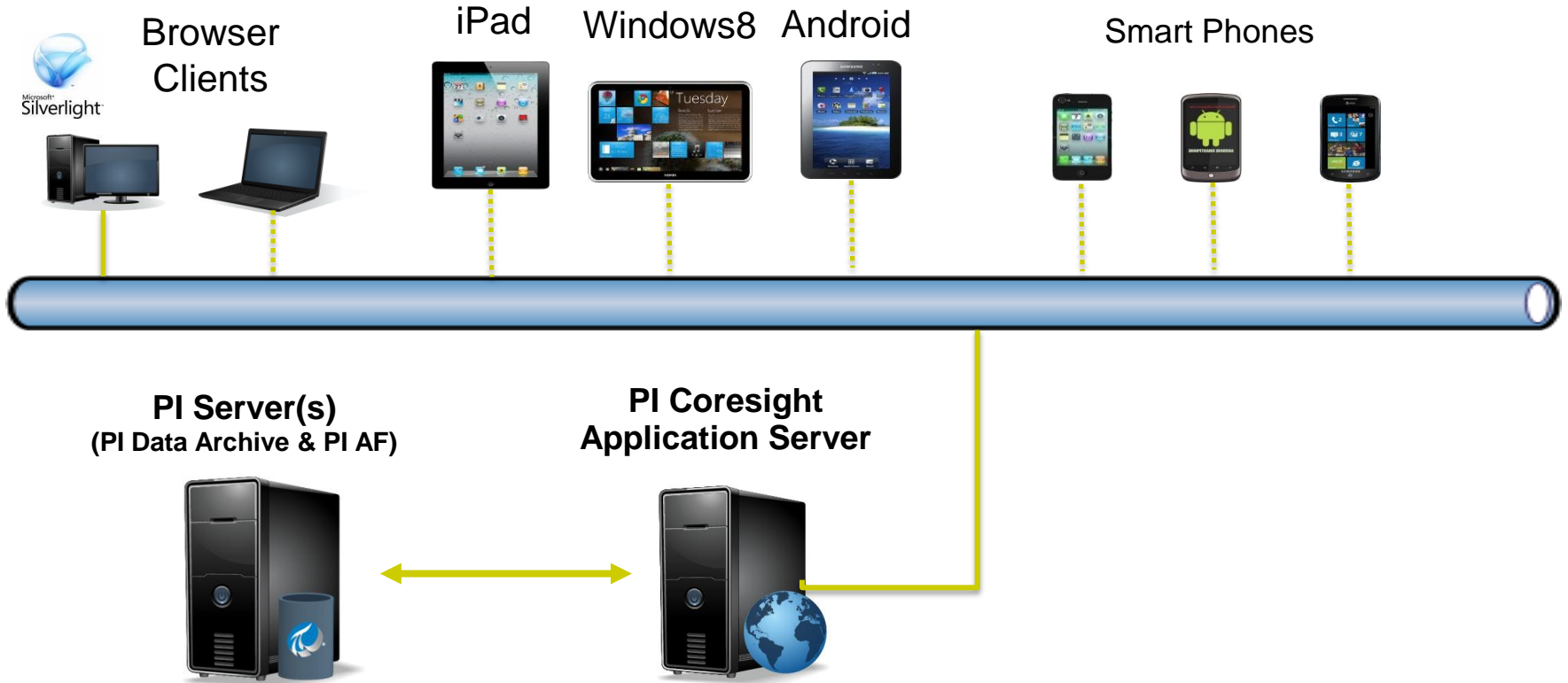

PI Coresight – ProcessBook Display Viewer

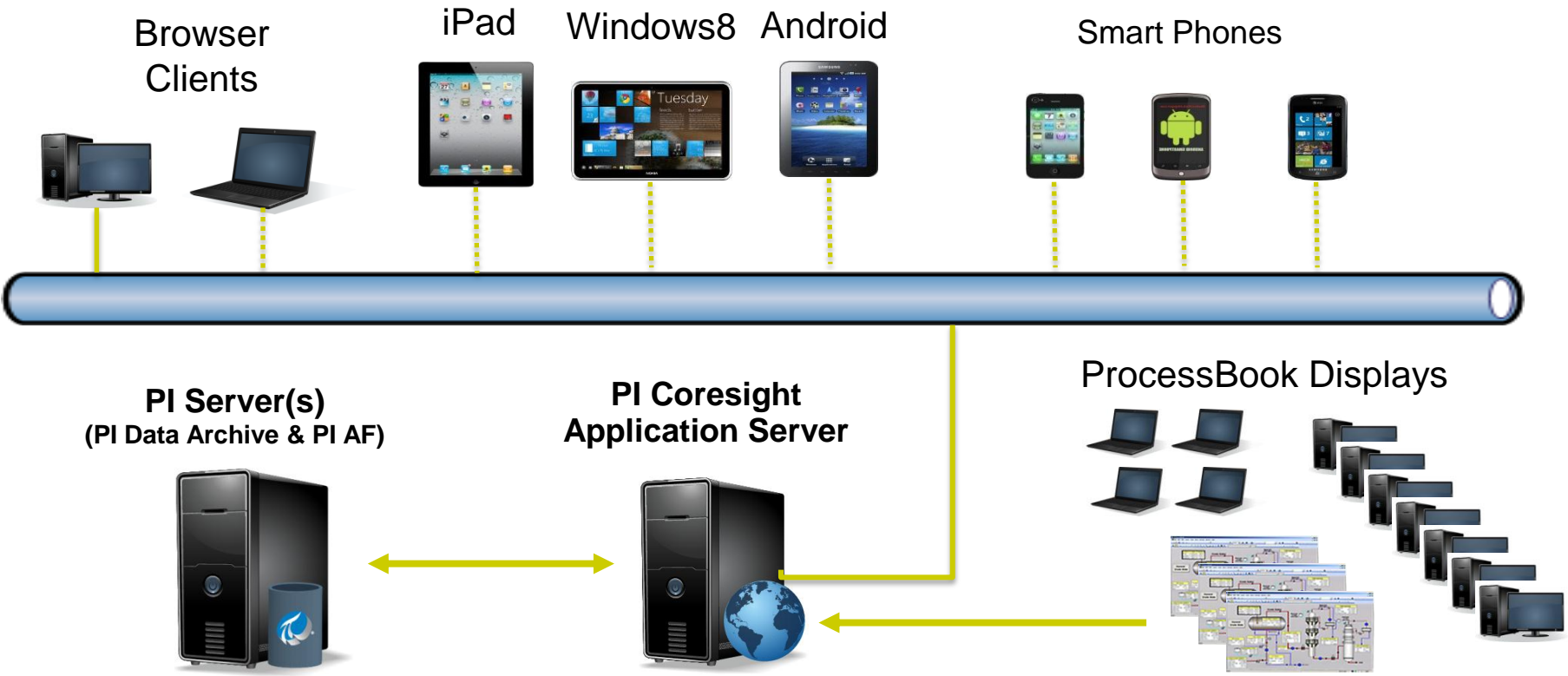

Stay Up-To-Date on the Web

- PI System Roadmap on OSIsoft Technical Support Site

<http://techsupport.osisoft.com/techsupport/NonTemplates/roadmap.aspx>

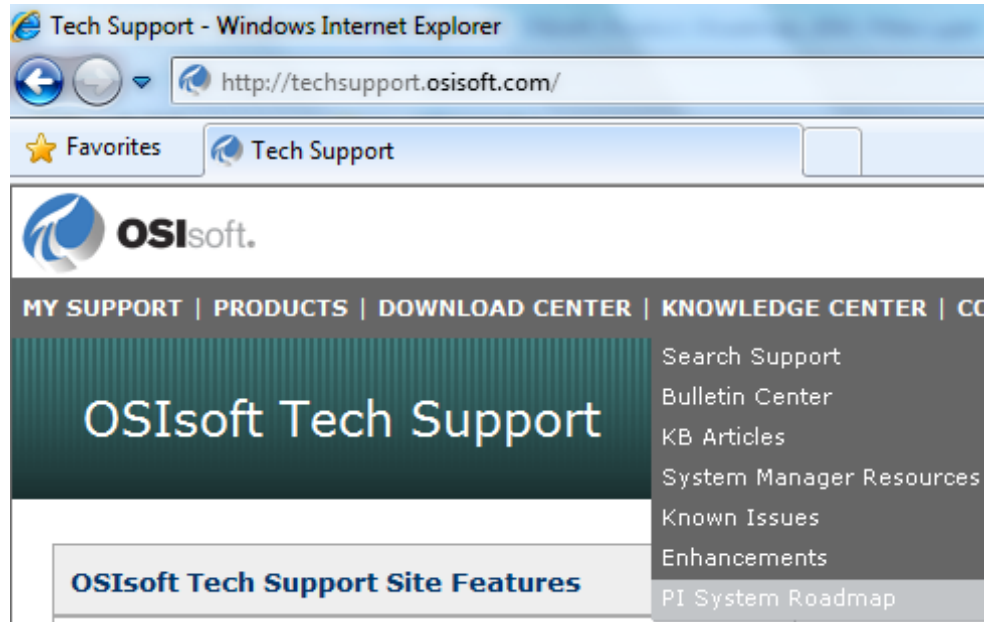

OSIssoft Learning Channel on YouTube

YouTube

OSIssoft Learning Channel
719 subscribers View channel +

Subscribed

All activity Uploads only

OSIssoft: Install PI Coresight. v1.0.0.6b 4 days ago
Start-to-finish installation on OSIssoft's PI Coresight
228 views
OSIssoftLearning uploaded + 2 more

PI ProcessBook (v3.0) 2 weeks ago
OSIssoftLearning added to a playlist
OSIssoft: Exercise Viewing PI notifica...
OSIssoft: Open the PI ProcessBook d...
OSIssoft: Send email and instant mes...
OSIssoft: Set the time range of opene...
OSIssoft: Use the Contacts window in...
OSIssoft: View notifications in PI Proc...

OSIssoft: Show Average, Maximum, & Minimum on a PI 2 weeks ago
[0:09] Add a statistic line to PI Coresight trend symbol
56 views
OSIssoftLearning uploaded + 1 more

OSIssoft: Build a Read-only PI Coresight display with Kiosk 2 weeks ago
[0:06] Introduction and Demonstration

On-Demand Learning at Your Fingertips

Watch us on YouTube

Who Should Be Using PI System Data?

- Renewable Energy Dispatch Operator
- Control Room Operator
- Operations Supervisor
- Operations Lead
- Transmission Dispatcher
- System Dispatch
- Pipeline Controller
- Planning/Reliability Engineer
- SCADA Engineer
- Power Operations Engineer
- Automation Engineer
- Project Engineer
- Control Systems Engineer
- Process Engineer
- Process Control Engineer
- Commercial Engineer
- MES/PIMS Engineer
- Technical Service Engineer
- PI System Engineer
- Real Time Systems Engineer
- Instrument and Control Engineer

- Market sales Manager Utilities
- EMS Supervisor
- Asset Management Program
- Mine Superintendent
- Division Manager
- Business Development Manager
- Supply Operations Supt.
- Program Manager, Pipeline & Power Industrial Control & Operating Environment
- Supervisor, EMS SCADA Systems
- Mgr, Plant I.T.
- Manager, Process Control & EIT Program, XPS
- Plant Optimization & NERC CIP Compliance Manager
- Process Controls Software Manager
- Director of Platform Product Management
- Electrical & Control Systems Manager
- Business Relationship Manager
- Control Syst. Suprv.
- Technical Services Supervisor
- Scale & Process Control Supervisor
- Maintenance Supervisor Process control/IT

- Gas Engineer
- Performance Engineer
- Operations Engineer
- Systems Engineer
- Electrical Engineer
- Utility Engineer
- Power Systems Engineer
- Reconciliation Engineer
- Reservoir Engineer
- Reliability Engineer
- Generation Engineer
- Plant Engineer
- Bioprocess Equipment Engineer
- Mechanical Engineer
- Domain Expert Engineering
- EMS Engineer
- Automation MES Engineer
- Process Development Engineer

- Financial Systems Analyst
- Reliability Analyst
- Principal Operations Systems Analyst
- Business Systems Analyst
- Senior Sustainability Advisor
- Business Analyst
- Energy Systems Analyst
- Performance Analyst
- Real-Time Analyst
- Senior Sourcing Analyst
- Analyst Industrial IT
- IT Analyst
- Energy Analyst
- Engineering Analyst
- Wind Resource Data Analyst
- Hydro Analyst
- Quality Analyst
- EMS Analyst
- Process Systems Analyst
- Mill Application Analyst
- Process Computing Analyst
- Operations Analyst

- PI Application Engineer
- Sr. Manager, O&M IT Applications
- IT Manager - Mill Applications
- Refining I.T. Manager
- Data Systems Administrator
- Application Support Analyst
- Manufacturing IT Architect
- Data Systems Analyst
- Director of Application Development
- Tech Support for Operations
- IT Director, Consumer Packaging
- Global PI - Business Solutions Architect
- Process Systems Application Engineer
- IT Business Partner
- Applications Support Lead
- Director, Sustainable IT
- Information Security Engineer
- Product Line Manager
- Control System Supervisor
- System performance manager
- DCS Supervisor

• Executives

- CEO
- CFO
- President
- Chief Sustainability Officer
- Vice President
- Director
- Chief Technical Officer
- VP Plant Operations
- VP Marketing
- CIO Manufacturing
- Vice President Product Development
- Vice President of Sales
- Chairman
- VP of Operations and COO
- Sales Director
- Vice President of Technical Services
- Vice President Client Sales and Marketing
- Vice President of Engineering
- Vice President, Strategy
- Vice President Contract Marketing
- Vice President Corporate Communications
- Vice President of Marketing & Business Dev.
- Vice President Facilities Equipment Health Management
- Vice President Program Management
- Vice President - Client Strategy and Solutions
- Vice President, Operations and Business Development
- Executive in Information Management /or Production Operator

- IT Applications Manager
- Plant Manager
- Maintenance Manager
- Global Production Volumes Manager
- PI System Manager
- Development Manager
- Maintenance Team Leader
- Product Engineering Mgr
- IT Operations Manager
- Managing Director
- Operations Manager
- Business Development Manager
- Central Heating & Cooling Plant Manager
- Global Production Services Manager
- Director, Midstream Operations North
- Director, Smart Network Operations
- IT - Director
- Hydro Generation Supervisor
- Manager, Data Analytics
- Infrastructure Manager
- Manufacturing Process Information Manager
- Program Manager

• Business Analysts

- Customers
- Public
- Contractors
- Vendors



THANK YOU

Brought to you by  **OSIsoft.**