



OSIsoft®

Regional Seminar Series



Architecture and Best Practices: Recommendations for PI Systems

Chris Coen
Product Manager
OSIsoft, LLC

Empowering Business in Real Time.

© Copyright 2010, OSIsoft, LLC. All rights Reserved.

- PI Server with Windows Integrated Security (WIS)
- PI High Availability
- PI Interface Failover
- Virtualization and PI

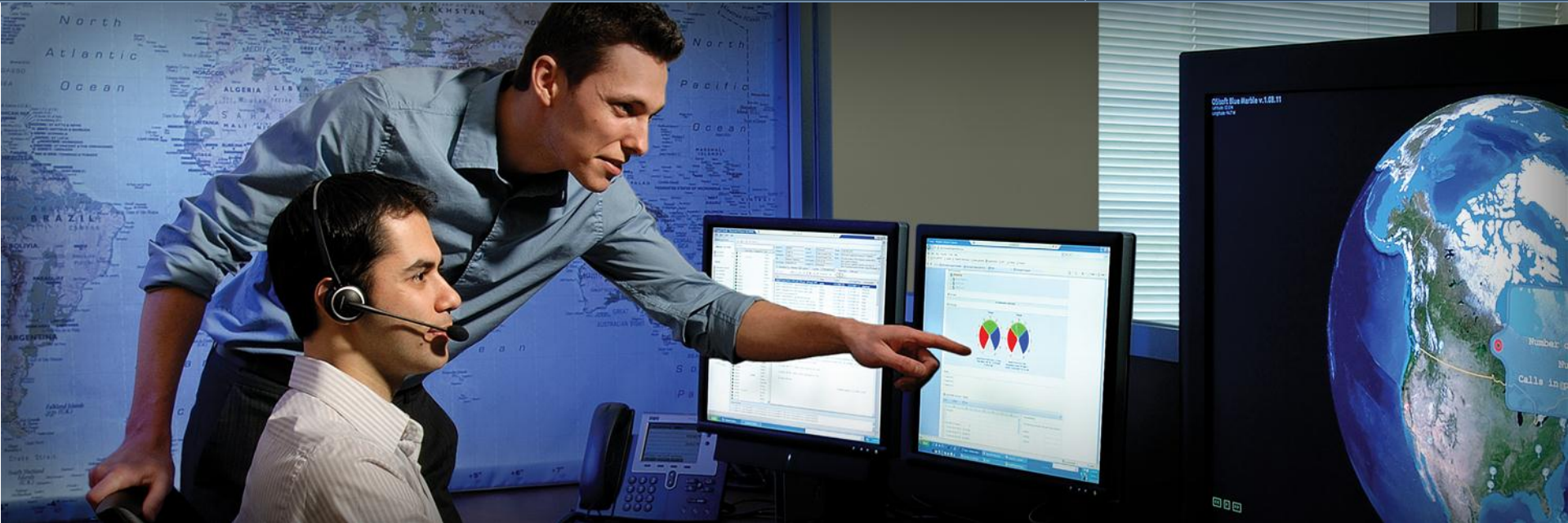

New PI Security Concepts

Empowering Business in Real Time.

© Copyright 2010, OSIsoft, LLC. All rights Reserved.

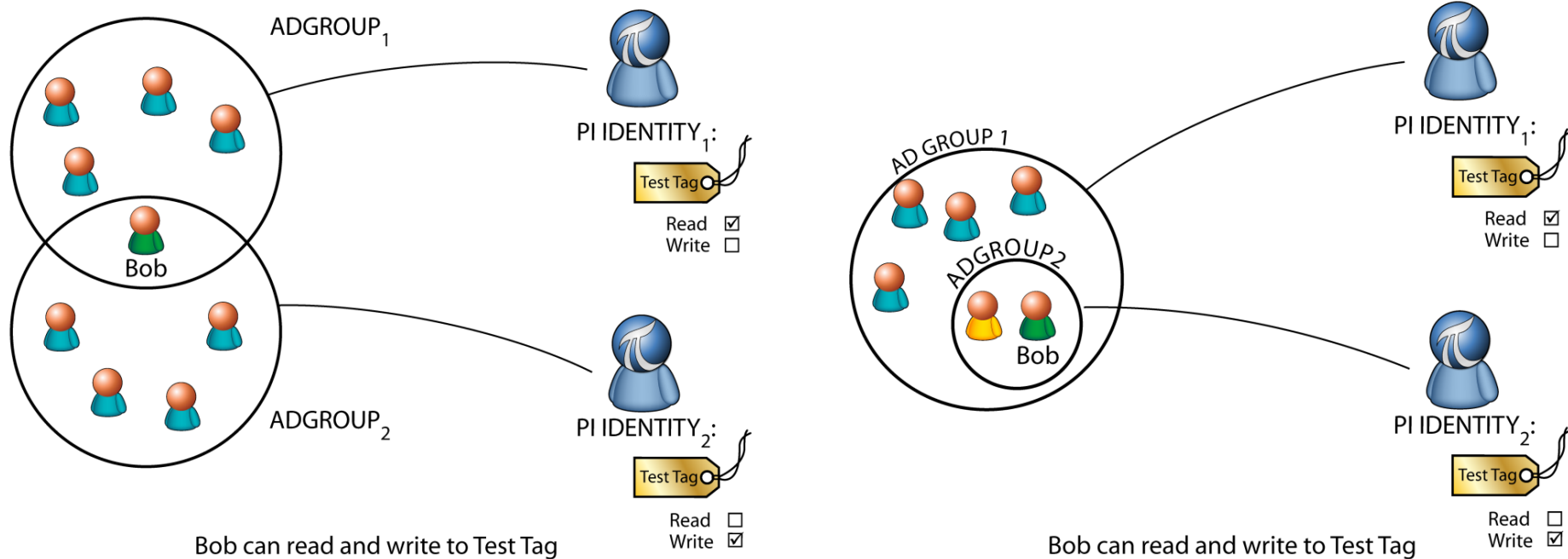

- PI Identities = Security Principals within PI
 - Examples: PIOperators, PIEngineers, and PISupervisors
- PI Mappings - link AD Groups to PI Identities

Old Model

Windows

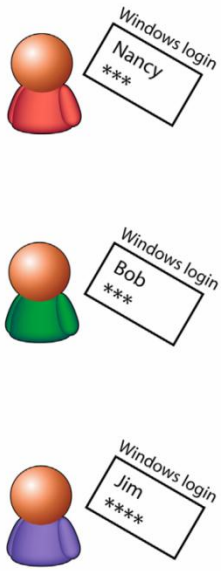

PI Server



- The security principal is the PI User
- Audit and Change logs reflect the PI User

New Model

Windows

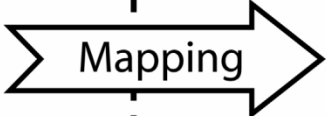
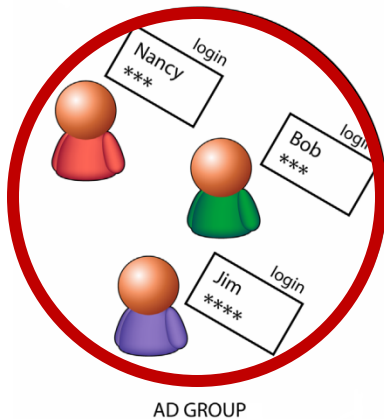

PI Server

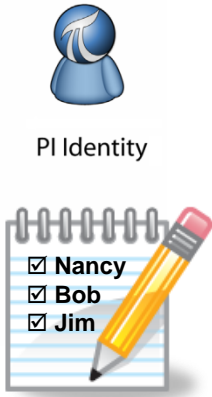

- The security principal is the Windows User, not a PI User
- Audit and Change logs in the PI Server reflect the Windows User

- Differences between PI Identity and PI Users and Groups
 - Unlike PI Users, PI identities don't have a password and can't be used for explicit login
 - Unlike PI Groups, PI Identities can not contain PI Users

- Common Properties Shared by PI Identities, Users, and Groups
 - Can be used for PI Mappings or PI Trusts (except PIWorld)
 - Can be used in all Access Control Lists (ACL)
 - Have the same authentication control flags

- PI Server must be a member of a domain to leverage Kerberos authentication
- Multiple AD domains must have trusts established or users and groups from other domain cannot be used
 - One-way trusts are supported: the server domain must trust the client domain
- Users in Workgroups can be configured to use Windows Local Groups from the PI Server machine
 - Passwords have to match for NTLM authentication

- Considerations when Integrating with AD
 - Kerberos authentication can be used without creating domain groups
 - Create a Local Group then add users from AD into those local groups
 - Who will manage the AD Security groups?
 - Will IT allow you to manage them?
 - Do you want to manage them?
 - Design Identity mappings and AD or Local Groups to ensure consistent access management across your PI System(s) with Active Directory

- Develop a PI Identity Scheme for your Organization
 - Protect your data
 - Ease of maintenance
 - Organizational separation
 - Standardize
- Consider Kerberos
 - Map AD principals directly
 - Map AD principals to local groups



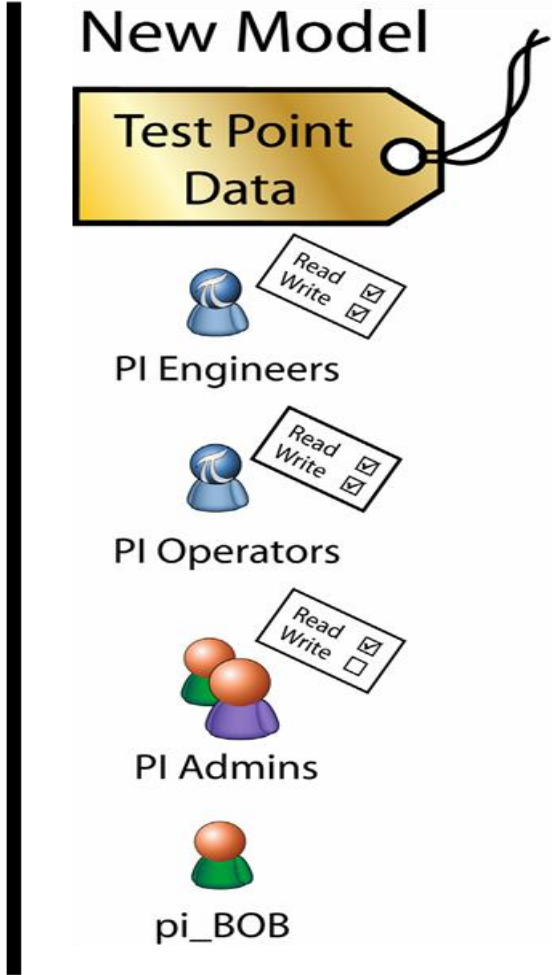
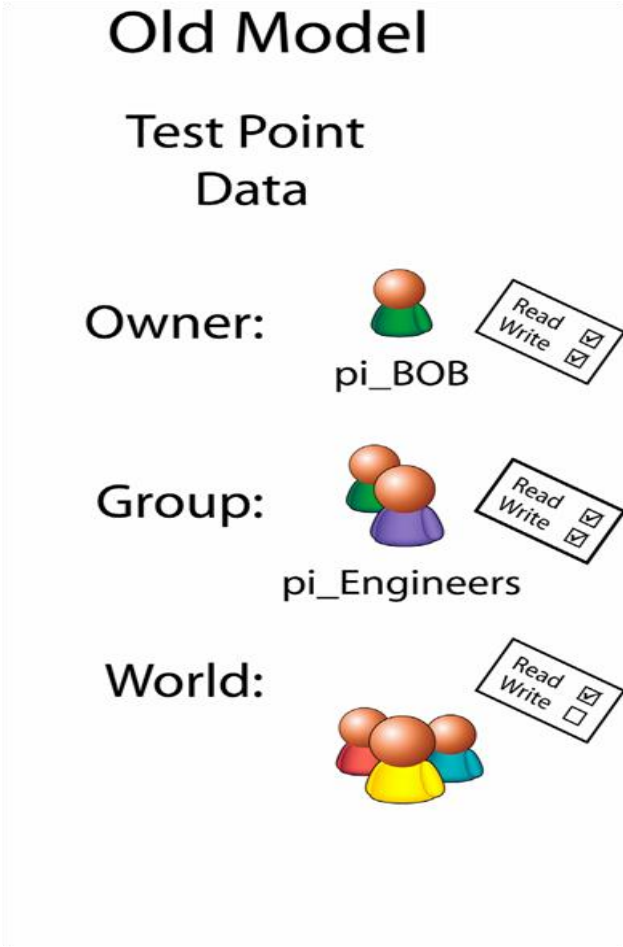

Tag	dataaccess	datagroup	dataowner
sinusoid	o:rw g:rw w:r	pi_users	bob



Tag	datasecurity
sinusoid	pi_users:A(r,w) bob:A(r,w) PIWorld:A(r)



- Everyone is granted at least PIWorld privileges
- World access is controlled through a PI Identity
- Default setting: read-only access
- You can disable PIWorld

- Clients
 - No more explicit logins
 - Seamless authentication from a Windows session
 - You can revert to the old method (explicit login) by selecting the authentication procedure in the SDK

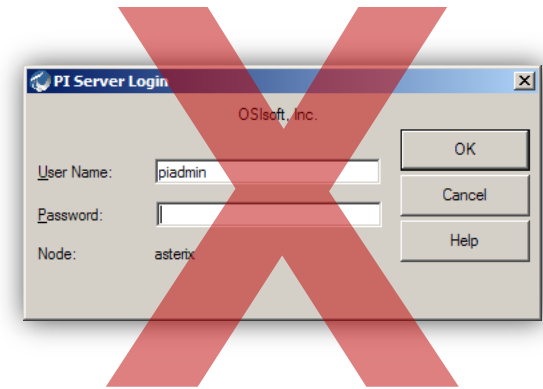

How to Tighten Security



1. Use the new Security Tool to help secure your PI Server
2. Disable or protect the PIADMIN account
3. Disable PI password authentication (Explicit Logins)
4. Secure piconfig by forcing login
5. Retire PI SDK-based Trusts
6. Configure the PI Server Firewall
7. Disable PIWorld Identity

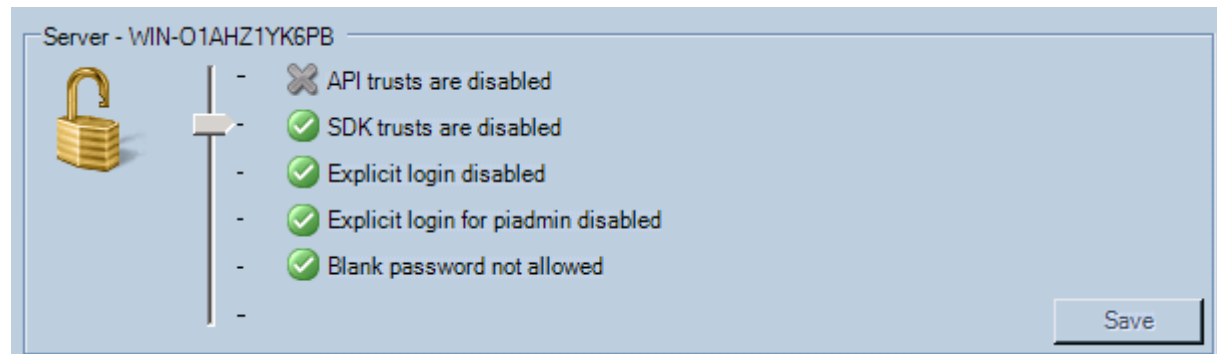

- Perform impact and risk analysis
- Work with the CoE to update your architecture
- Develop a migration plan with EPM
 1. Identify access roles “read-only” & “read-write”
 2. Create PI Identities
 3. Create AD Groups
 4. Create PI Mappings
 5. Plan for AD Group Maintenance (add/remove users)



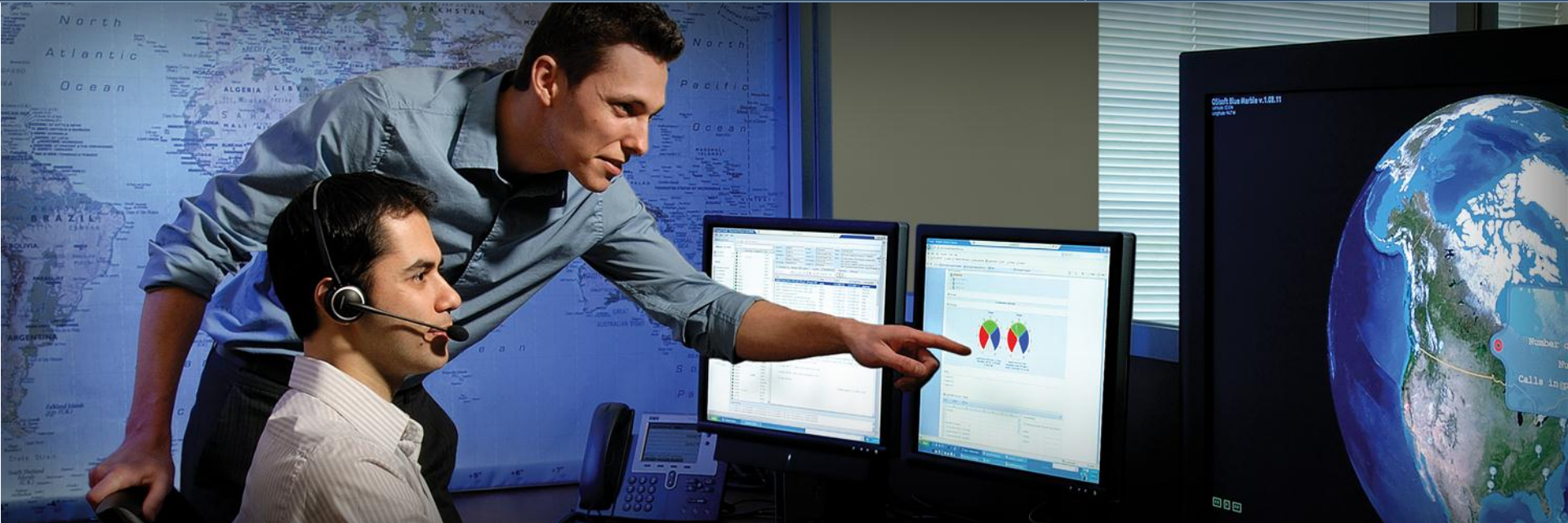

PI High Availability (HA)

Empowering Business in Real Time.

© Copyright 2010, OSIsoft, LLC. All rights Reserved.

PI High Availability Architecture

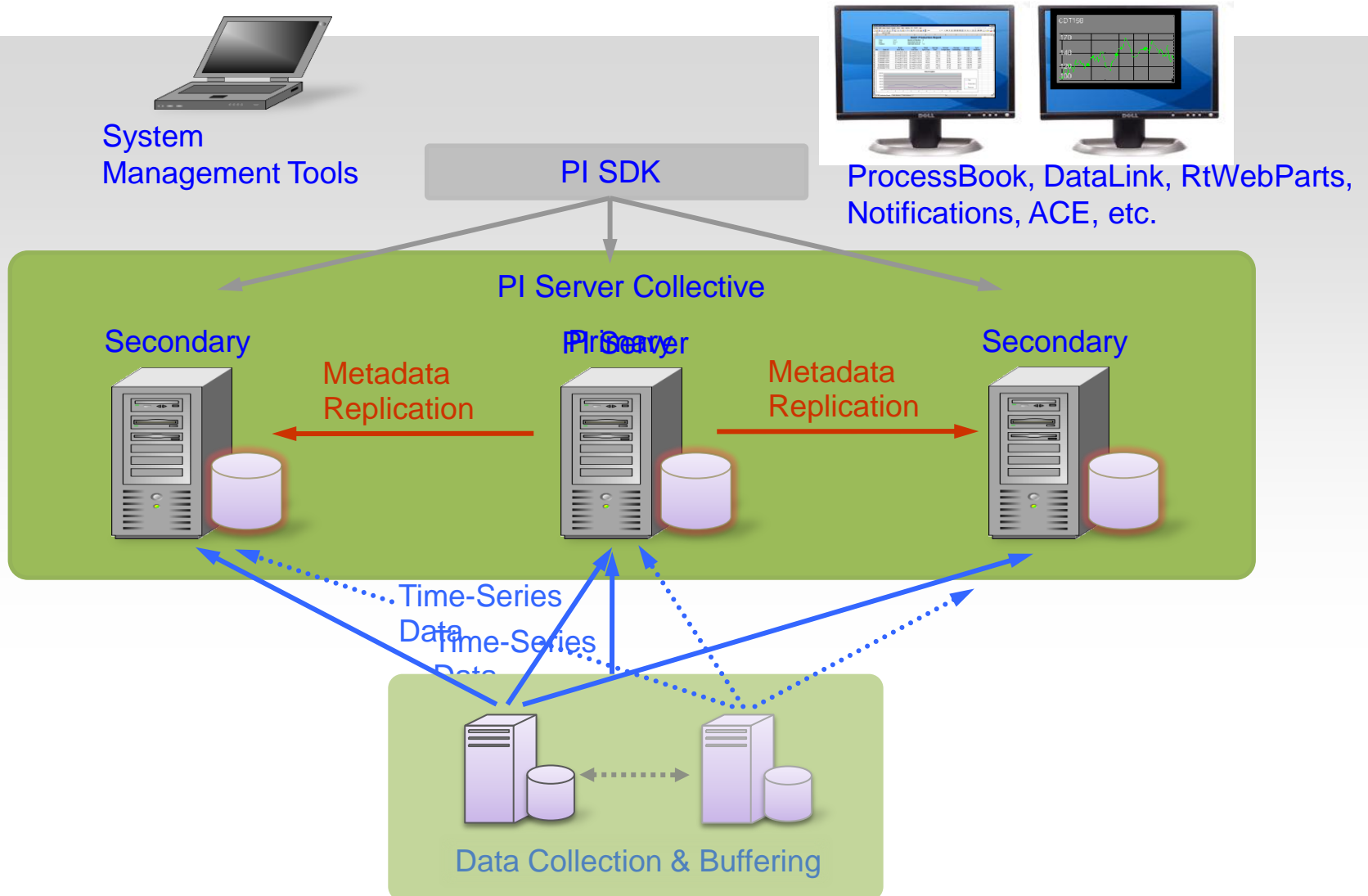

- PI is there all the time - users trust it
- No late night heroics to restore a backup or perform routine maintenance
- Removes fear of a bad backup
- Simple design is robust, low bandwidth and supported by WANs
- Geographical independence (replace PI to PI)
- Support more or specialized users
- Facilitates capacity planning
- Complements virtualization strategies:
 - PI is perfect for monitoring a virtualized environment (HyperV performance counters; VMWare SNMP interface)

- Transmission & Distribution customers cannot lose visibility or the grid can go down (e.g., Cal ISO)
- Dispersed sites can deploy collective members in each location for better client retrieval performance without losing synchronization (International Paper)
- Load balance the data retrieval by users (PJM, Cal ISO)
- Aggregate data into one large PI system (PSE&G)
- Load Balancing and Failover for virtual machines
- NERC CIP: dedicated PI server inside the security perimeter



PI Interface Failover

Empowering Business in Real Time.

© Copyright 2010, OSIsoft, LLC. All rights Reserved.

Native Data Source Failover for Data Collection

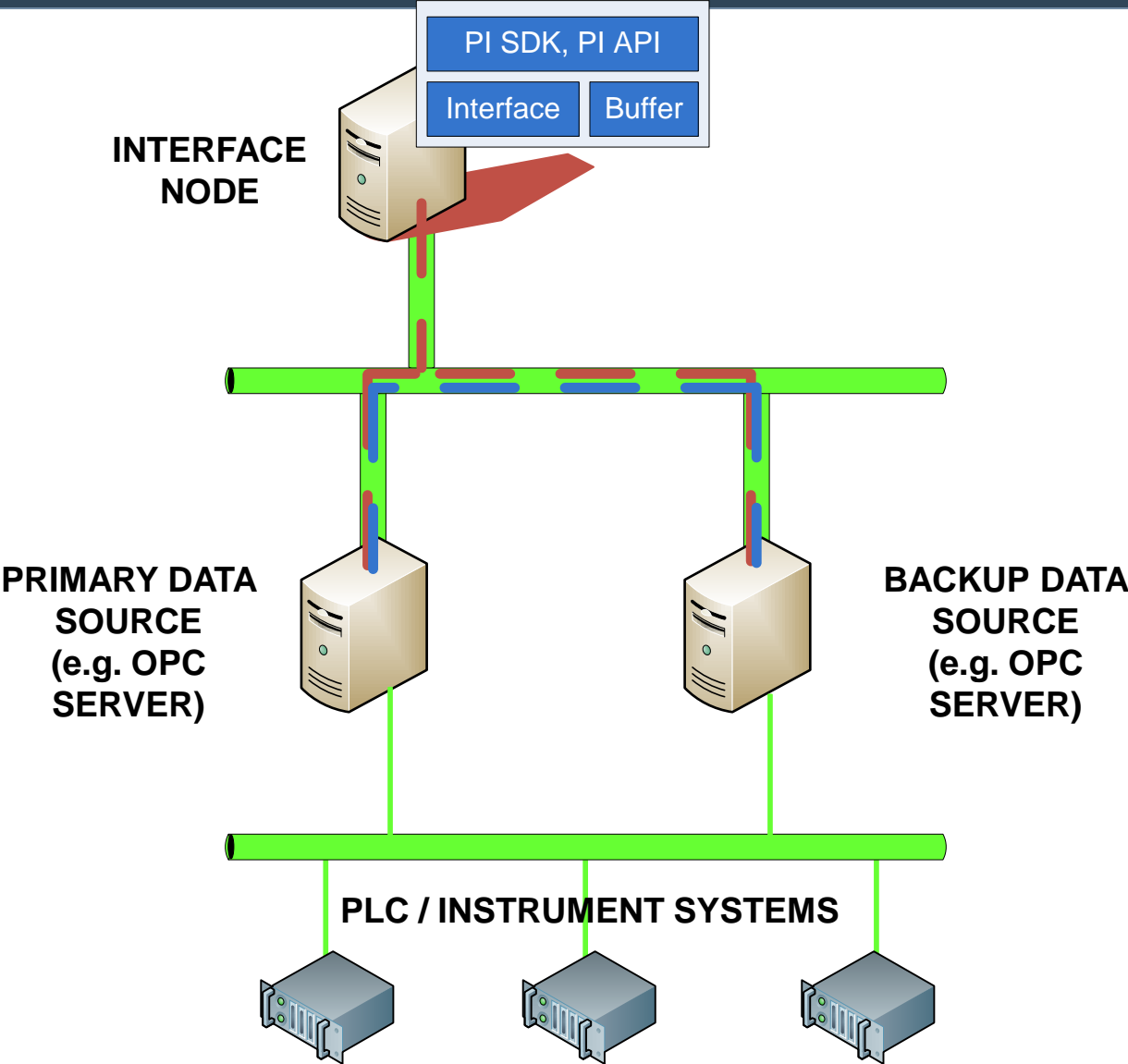

Interface Failover for Data Collection

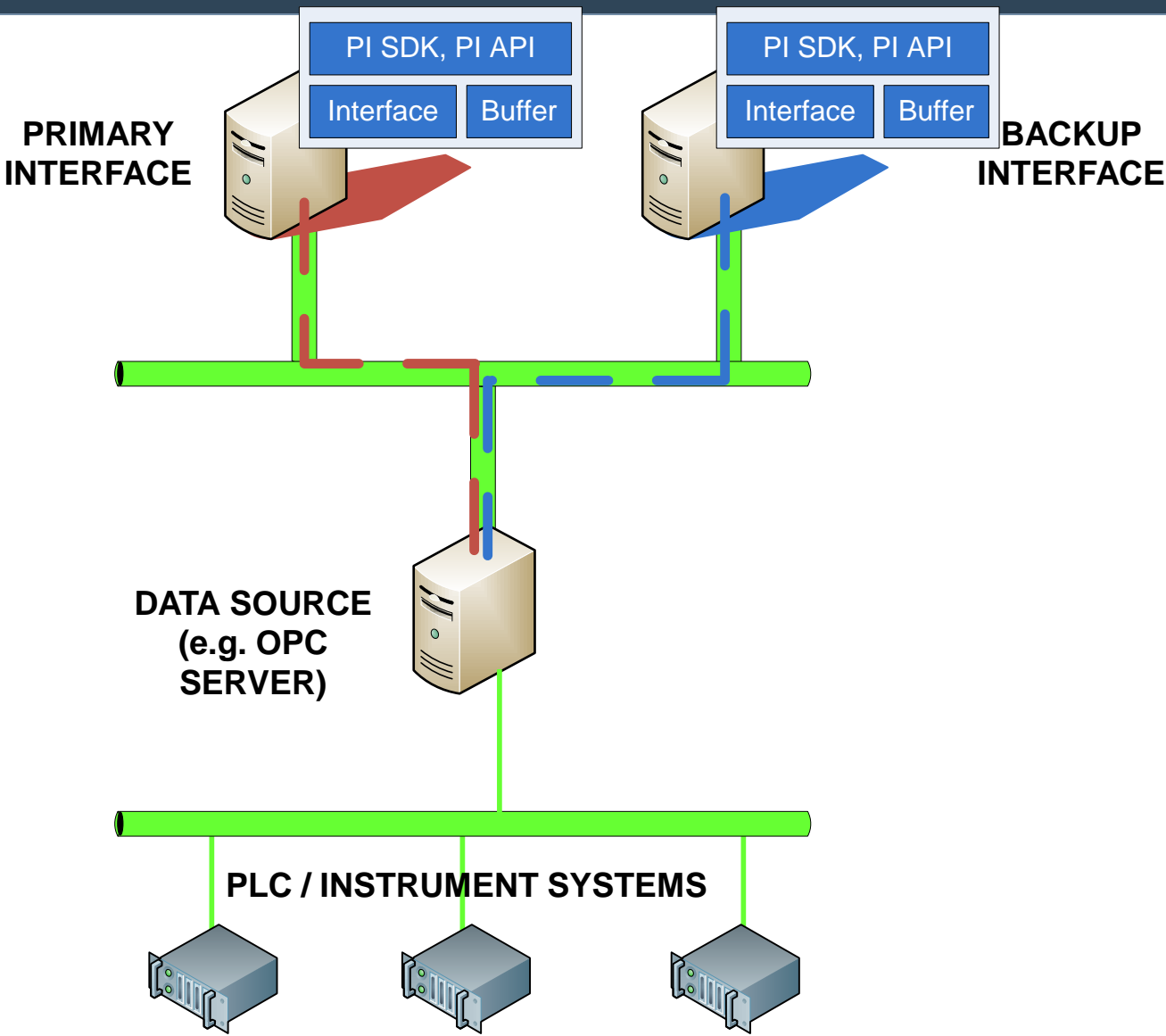

Combination of native Data Source and Interface Failover

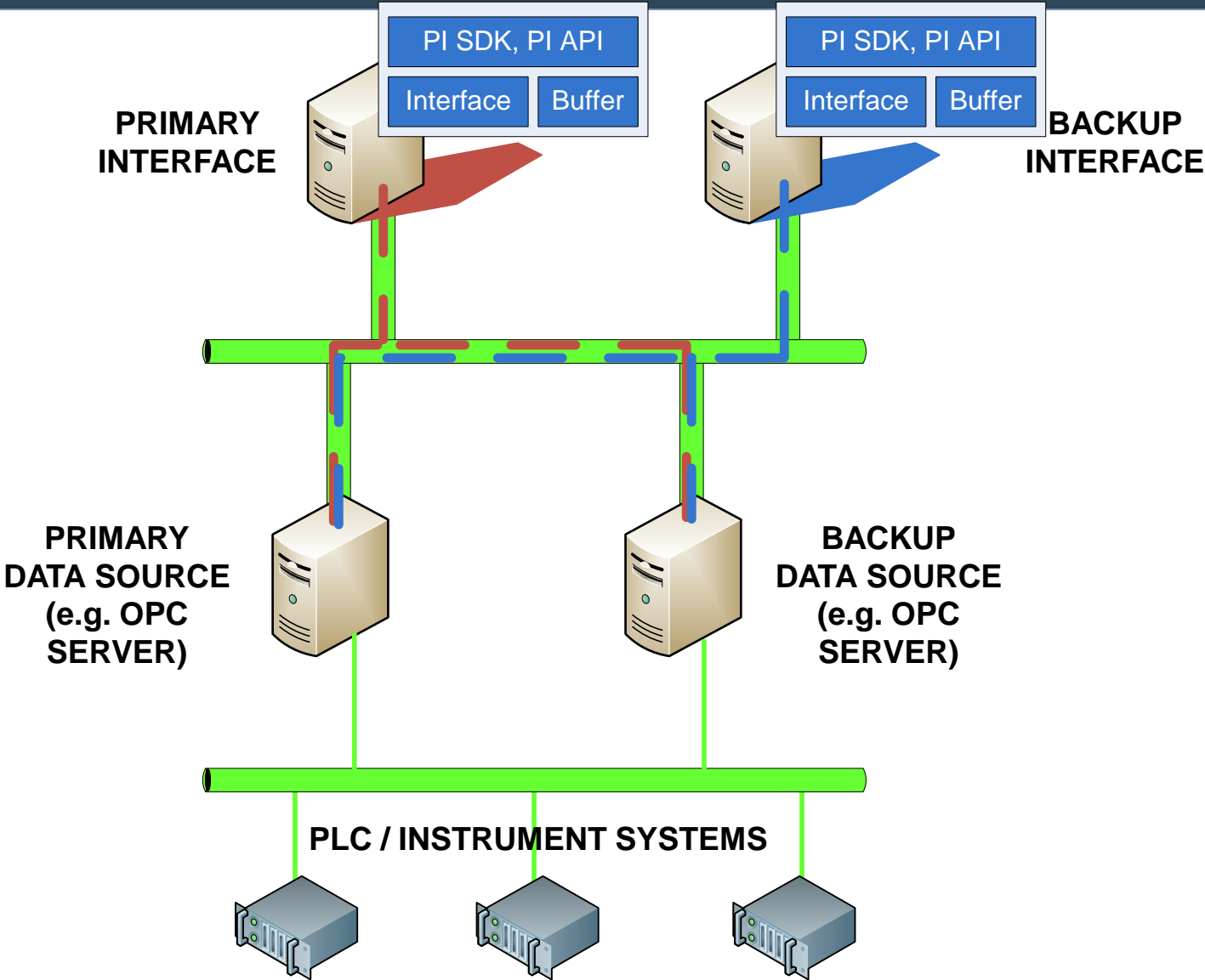

- Phase 1
 - Maintains heartbeat via source data system
 - Only available for selected interfaces
- Phase 2
 - Maintain heartbeat via shared file
 - Many interfaces implement
 - OSIsoft recommended

- Interface failover provides
 - 2 instances collecting the same data from the data source.
 - Communication mechanism between 2 instances of the interface.
 - Backup interface is sleeping; it means no data is sent to PI.
 - If one fails the other will recognize it, wake up and start sending data to PI.

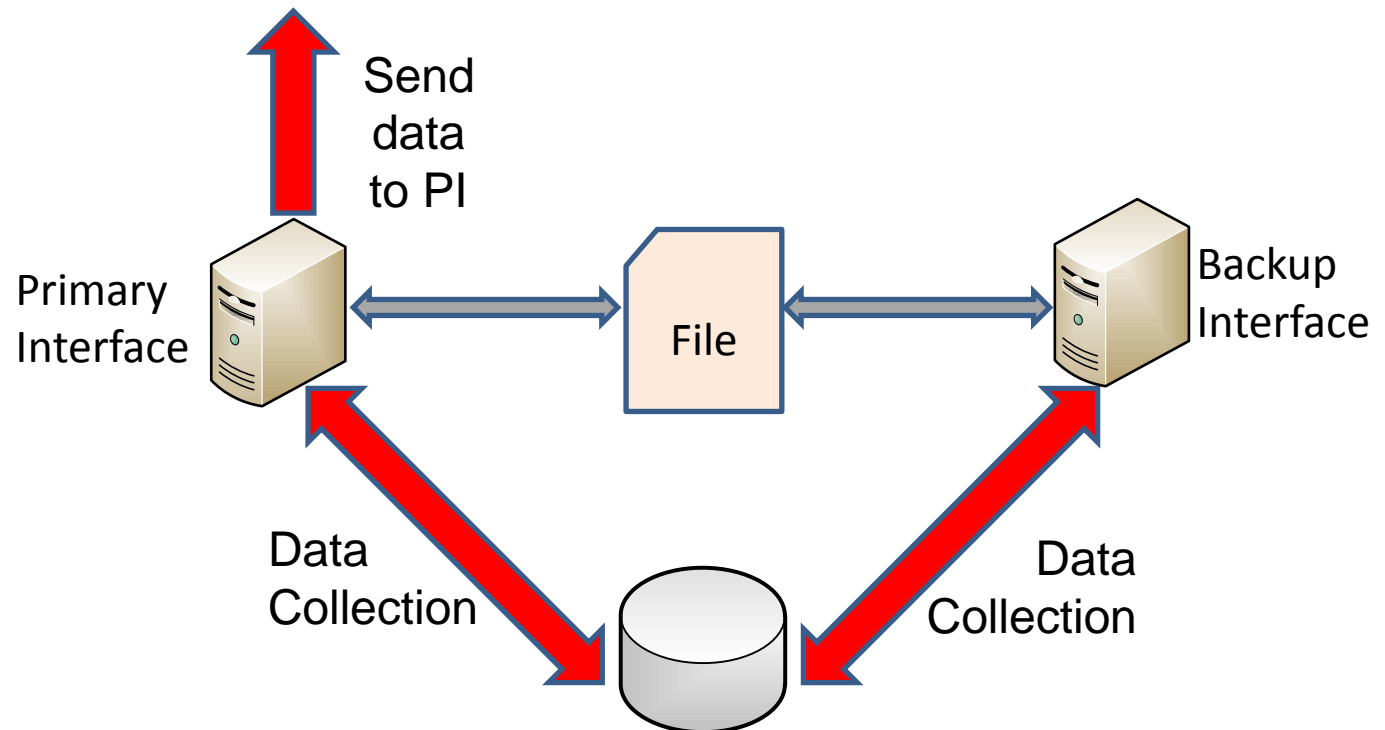

- Interfaces “watch” each other’s **Heartbeat and Status**
- Failover Types
 - **Hot** = No data loss
 - **Warm** = Maybe data loss
 - **Cold** = Some data lost

Hot Failover Example

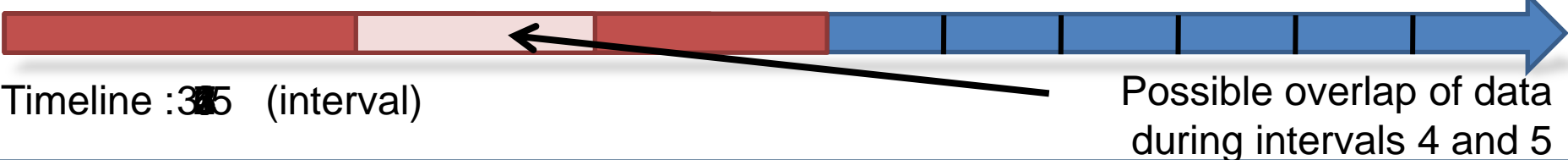
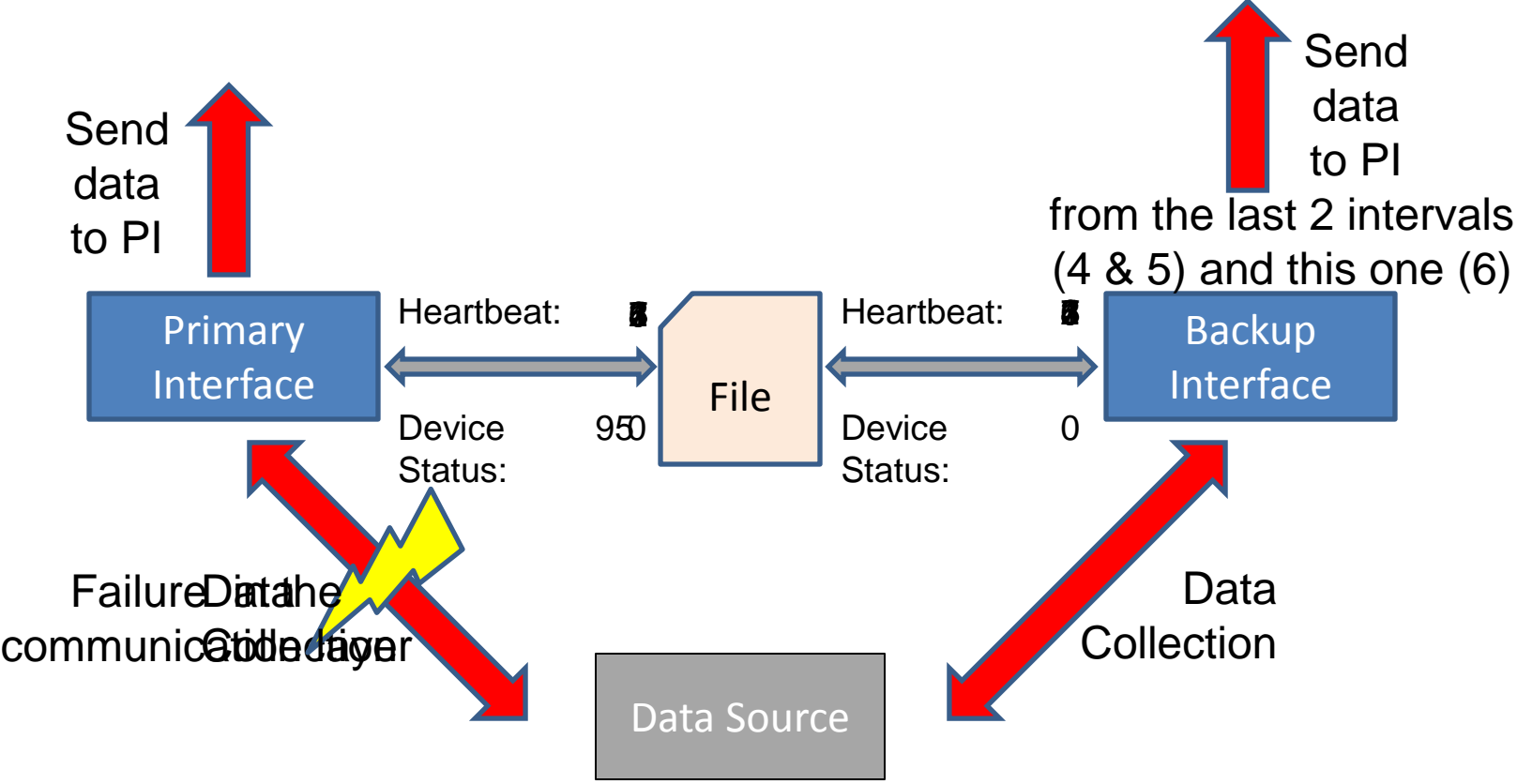

- Make a plan
 - Verify the PLC and/or instrument systems can support doubling the requests, including license requirements.
 - Determine heartbeat interval. Ensure long enough to prevent false failover.
- Hardware will be needed
 - Computers for file sharing system for heartbeat and the backup interface node.
 - Supplemental networking equipment.
 - 3rd party software and hardware might be required.
- Security
 - Manage the security on computer for the file sharing system.

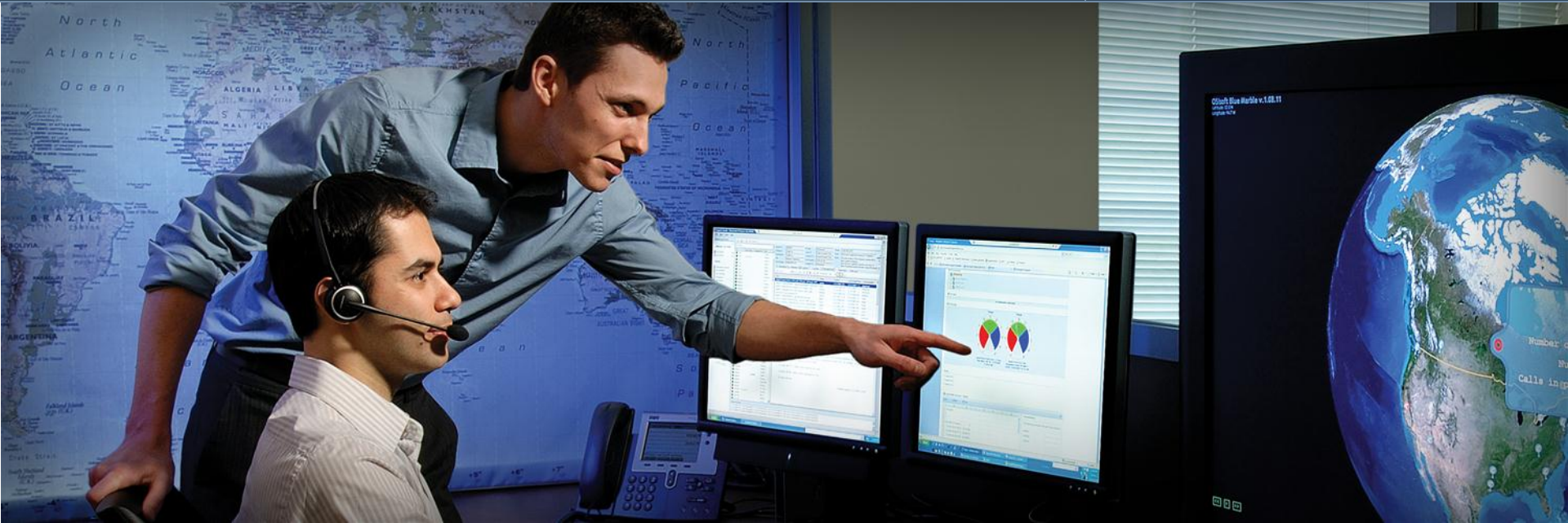

PI and Virtualization

Empowering Business in Real Time.

© Copyright 2010, OSIsoft, LLC. All rights Reserved.

- Servers
- Storage
- Applications

- Instead of having physical machines, virtual servers run on a physical host
- Case Study: AtlantiCare
 - Eliminated need to expand or relocate data center
 - Microsoft® Virtual Server 2005 used to consolidate infrastructure and legacy application servers
 - Consolidation ratio achieved of 33:2

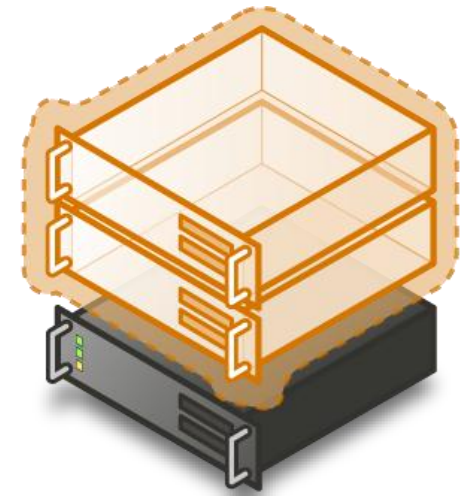

Example: Server Consolidation

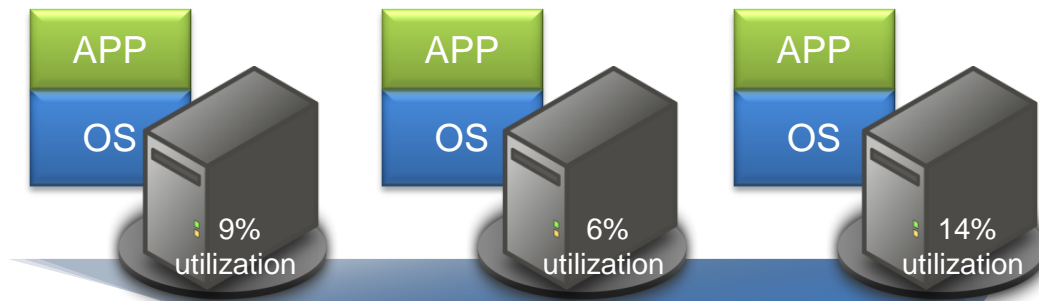

Typically server workloads only consume a small fraction of total physical server capacity, wasting hardware, space, and electricity

Through virtualization, these workloads can be consolidated onto fewer physical servers, saving resources and increasing flexibility

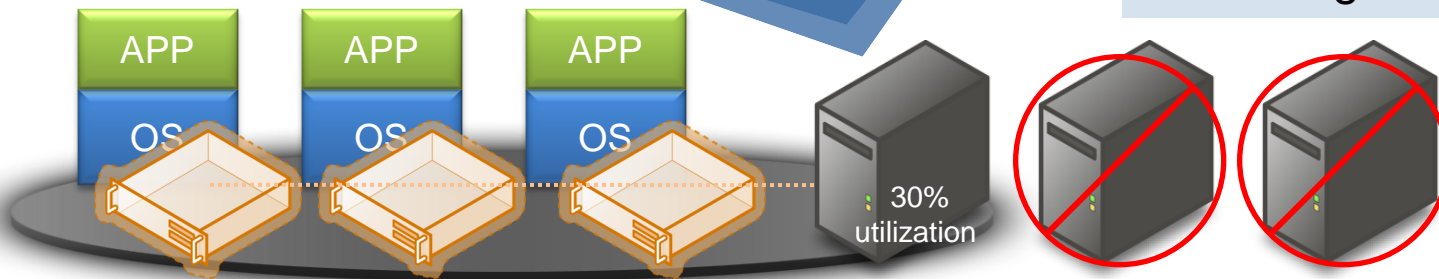

- Less hardware required (HP went from 85 data centers to 6)
 - up to 35% reduction of annual server costs per user (\$100-\$200K per year per server)
- Better utilization of hardware (HP decreased servers by 40%)
- Reduce power consumption (HP reduced energy by 40%)
- Provide higher availability by supporting redundancy
- Rapidly deliver adaptive and reliable IT services
- Tie diverse components together into a single managed entity
- Storage efficiency can lead to higher storage utilization

*Gillen, A., Grieser, T., Perry, R. 2008. Business Value of Virtualization: Realizing the Benefits of Integrated solutions. IDC.

Virtualized PI

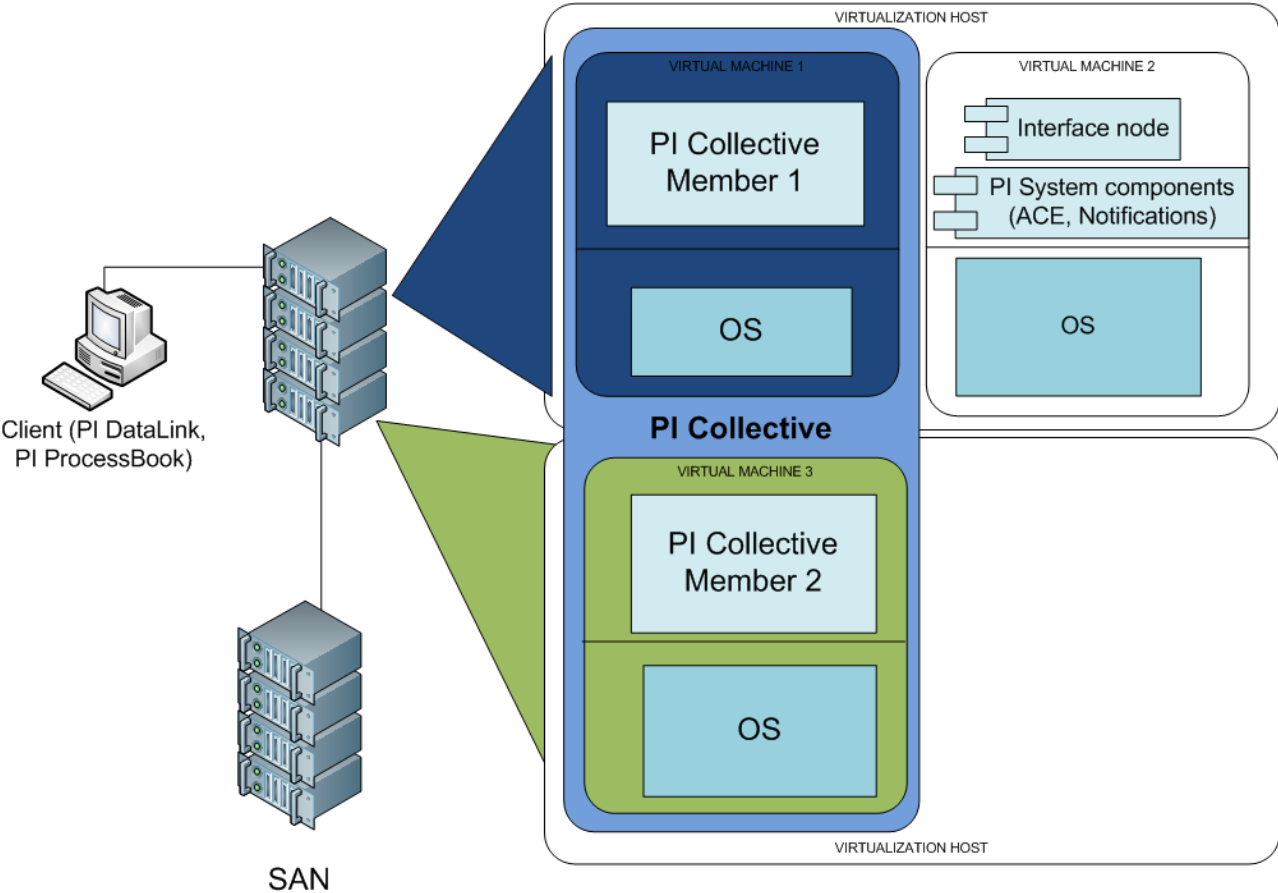

Recommendation: Virtualized PI System



- Multiple hosts (cluster)
- Collective can be split across hosts
- PI Server components can run as separate virtual machines for scalability and performance
- SAN can offload storage

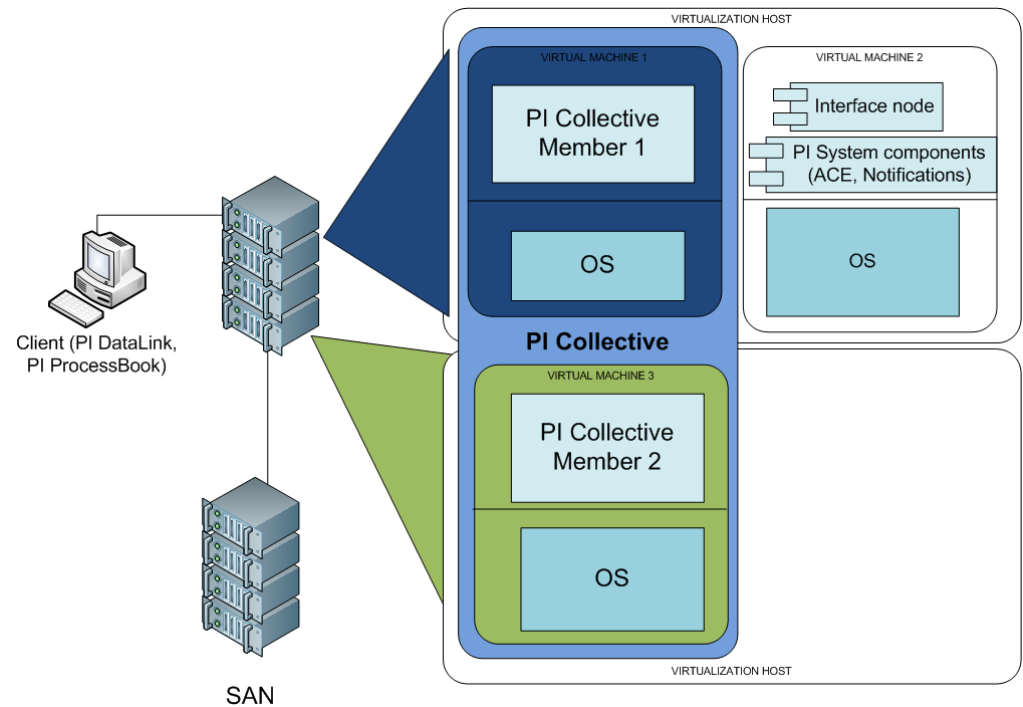

- Validated environments need a test bed (any pharmaceutical company; BMS; Shell)
- Environments that require portability of IT assets (Cargill Deicing Technology - Salt mining)
- Deploying new sites (Rio Tinto)
- Flexibility in assigning resources (OSIsoft NOC for monitoring EA PI Systems)

- **Challenge:**

Grow available storage space without disrupting applications and servers

- **Solution:**

Storage Area Networks (SAN) allow dynamic sizing of available storage

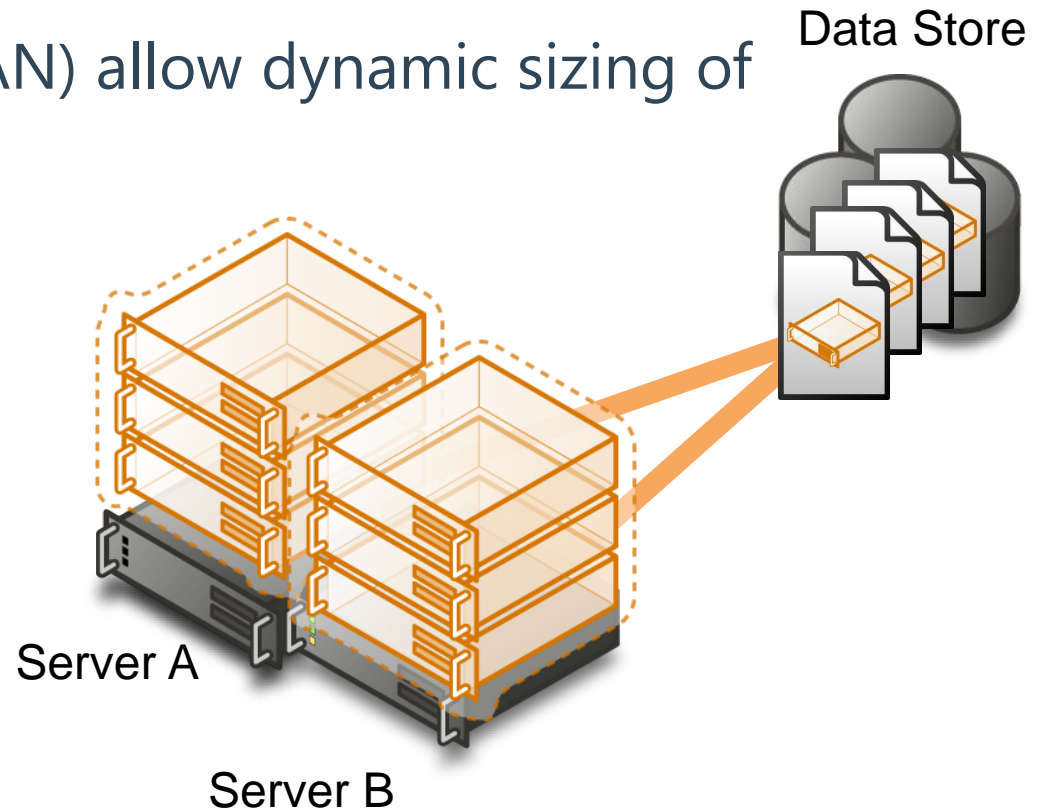

- Additional storage appears to be local to the host so users don't have to know where the files are stored
- Improve the ties between centralized storage and virtual infrastructure
- Provide virtual-machine consistent backups for data stores and the ability to restore virtual machines in a few clicks
- Provide relief from disk subsystem access in virtualized environments (biggest performance hit on virtual host)
- Consolidate disk resources

- Keep more and higher fidelity data online; add or expand PI archive files
- Support aggregated PI Systems; VSS support enables PI backups
- Store PI Client files centrally
- Backup virtualized application and data servers
- Backup virtualized Terminal Server hosts
- Complete system backup storage

Application Virtualization

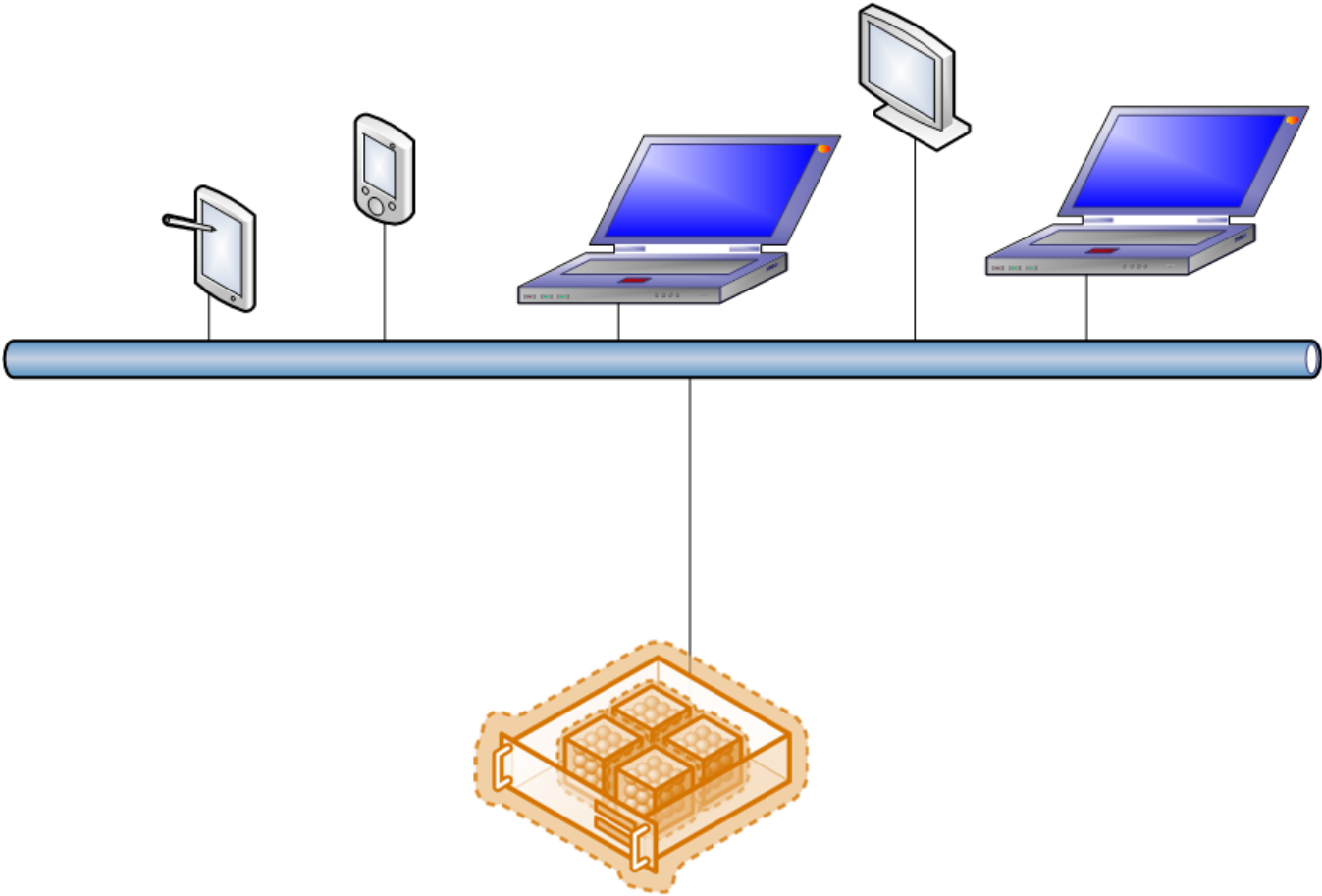

PI and Application Virtualization (ProcessBook)

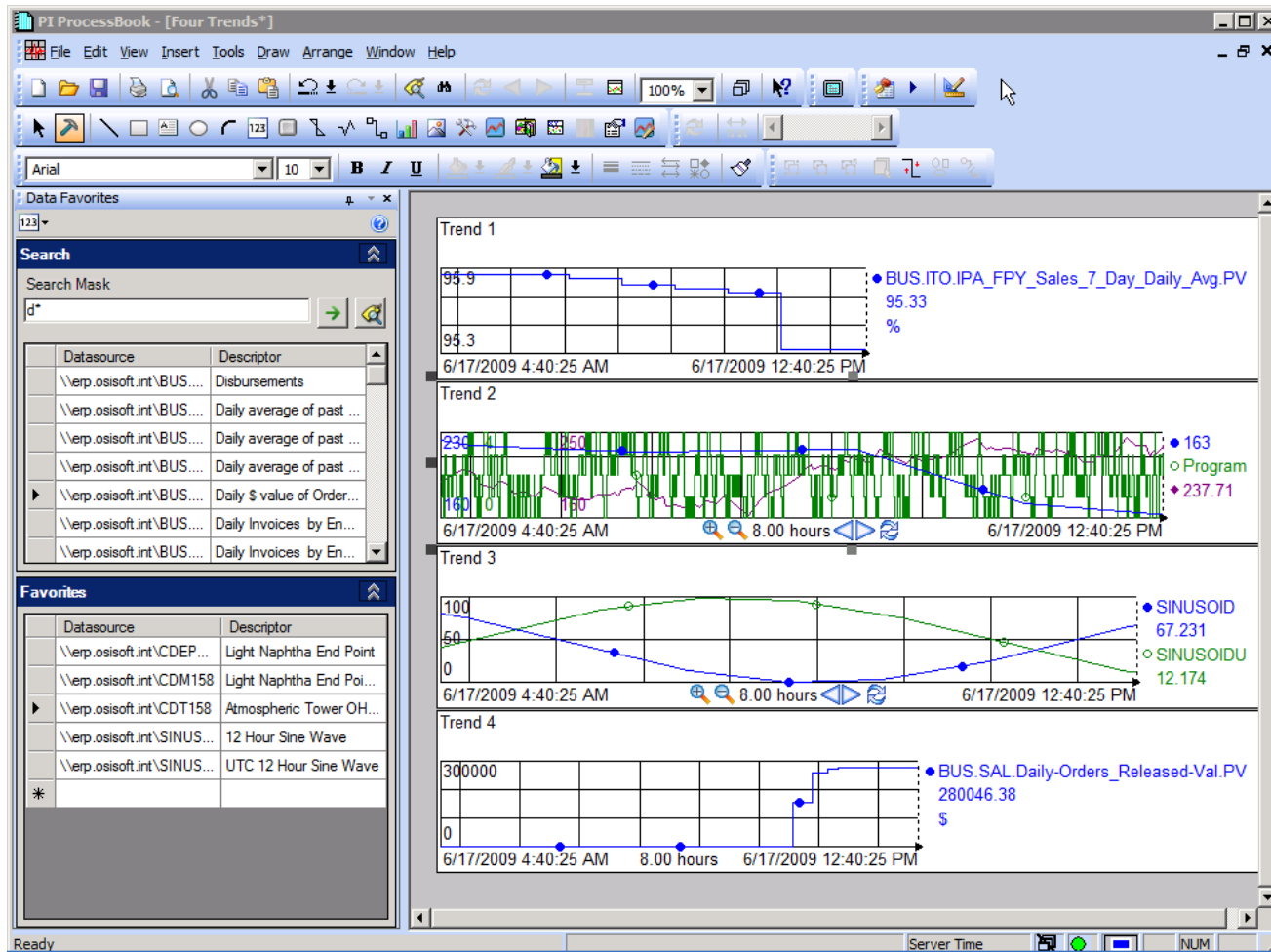

- Citrix or Terminal Server can reduce deployment costs and maintenance for client apps
- Windows 2008 Server offers a service that provides applications over an SSL connection (HTTPS) without client-side deployment (a thin deployment) - Terminal Services Gateway
- Terminal Services Gateway provides URL access to a host (like Remote Desktop connections, without the VPN requirement) or to specific applications on a host (even more secure for those outside the firewall)



- One point of installation makes deployment simpler
- Access to applications secured
- All users have the same version of the software; no version or compatibility issues
- Casual users do not need to install anything to get started
- Save money on hardware upgrade investments by deploying client software in one place

- Environments with casual client users who need low barrier to entry for system access (Inco Limited)
- Terminal Server users (a partial list)
 - Georgia Pacific, Kellogg, SASO, SAPPI Fine Paper, Wacker Chemie, Alcoa, Eli Lilly, ExxonMobil Upstream, Iberdrola, Progress Energy Services
- Citrix users (a partial list)
 - SDG&E , Water Corporation, Amgen, Bayer Material Science, Genmab, PPG, Vaxgen, Katahdin Paper, Celanese Chemicals, Novo Nordisk, Queensland Alumina, Total
- Windows 2008 Terminal Services Gateway
 - OSIsoft

- Treat virtual machines as if they were physical machines
- Invest in Enterprise-level hardware and software
- Do not mix virtual and physical on the same host
- Use qualified Virtualization support personnel
- Test on the target platform

*OSIsoft Center of Excellence

- PI works as well in a virtual environment as it does on physical hardware
- PI is perfect for monitoring a virtualized environment
- If you are thinking about virtualization, it's a good time to consider the value of HA PI
- If you are thinking about network storage, it's a good time to consider the value of virtualization and PI with SAN support
- If you are thinking about problems with client software deployment, it's a good time to consider the value of Terminal Services Gateway, virtualization and PI

- Whitepapers and Tech Support bulletins on OSIsoft web site
- Vendor web sites
- OSIsoft internal expertise
- Microsoft representatives for Hyper V and Terminal Server Gateway solutions



Thank you

© Copyright 2010 OSIsoft, LLC.

777 Davis St., Suite 250 San Leandro, CA 94577