



2003
OSISOFT USERS CONFERENCE

ProTRAQ™ ***Vendor-Managed Inventory***

Roland Heersink

CEO, Industrial Evolution

Gene Sullivan

Director of Sales, ChemLogix

OSIsoft ProTRAQ Moves to #1

- *ChemLogix & Industrial Evolution announce...*
 - *OSIsoft builds software*
 - *PI, ProTRAQ, ICE, MDB, ACE, RLINK, etc.*
 - *Industrial Evolution provides hosting service*
 - *Data storage, web page displays, secure access*
 - *ChemLogix delivers hardware & field services*
 - *Installation, configuration, support*
- *ChemLogix migrating its Web*VMI service to the ProTRAQ service!*



ProTRAQ VMI: The World Leader

2003 OSISOFT USERS CONFERENCE SAN FRANCISCO CALIFORNIA USA

ProTRAQ – Presentation Overview

- *ProTRAQ – path to world leadership*
- *What is Vendor Managed Inventory?*
- *Why do manufacturers implement VMI?*
- *The VMI solution set*
 - *Field data collection*
 - *Data hosting*
 - *ProTRAQ inventory management application*
 - *Vendor/customer interactions*
 - *Business systems integration*
- *BASF: A case study*
- *Installed base*

ProTRAQ – Path to World Leadership

- 2000
 - *ProTRAQ acquired by OSIsoft from Quaker Chemical*
- 2001
 - *ProTRAQ delivered as a VAX-based service to customers*
- 2002
 - *ProTRAQ integrated with ACE & ICE*
 - *Delivered as a web service from Industrial Evolution*
- 2003
 - *ProTRAQ to be delivered to all ChemLogix customers as part of alliance deal with Industrial Evolution*
 - *By year-end, ProTRAQ will be running on 1,000 tanks*

What is Vendor Managed Inventory?

A collaborative supply chain initiative

- *Collection & centralization of inventory data*
- *Remote access to collected data*
- *Integrates inventory data & business systems*



ProTRAQ VMI: The World Leader

2003 OSISOFT USERS CONFERENCE SAN FRANCISCO CALIFORNIA USA

What is Vendor Managed Inventory?



ProTRAQ VMI: The World Leader

VMI as a Business Tool

- *Common user software environment for Vendor and Customer use*
- *All components supported as single entity regardless of location*



ProTRAQ VMI: The World Leader

The VMI Business Model

- *Customer / vendor collaboration means proactive product management, not reactive*
- *Higher customer loyalty; lower costs on both sides*
- *Outsourced inventory ownership (Walmart model)*
- *Higher product performance guarantees possible*



ProTRAQ VMI: The World Leader

VMI is a Service

- *Product vendor (supplier) holds service contracts with customers, not just product P.O.'s*
- *A 3rd-party VMI provider typically manages data collection & access for use by product personnel*



ProTRAQ VMI: The World Leader

Two Types of VMI

In-Bound VMI

- *Management of raw material inventories at your plant by your suppliers*

Out-Bound VMI

- *Management of product inventories at your customer sites by your own personnel*

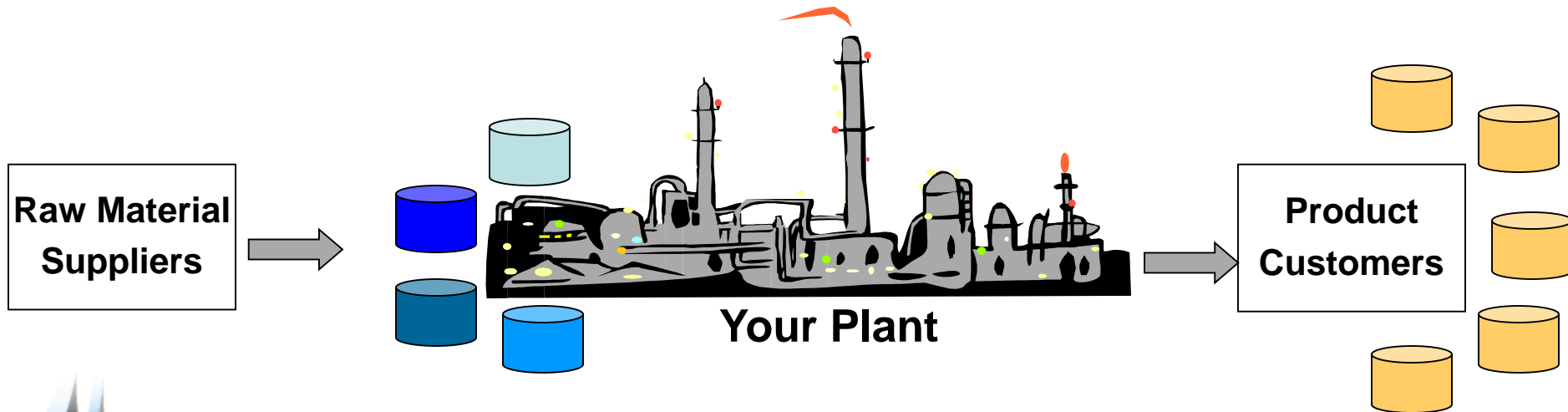

ProTRAQ VMI: The World Leader

VMI Benefits both Consumer & Vendor

Consumer Benefits

- *Reduced working capital*
- *Lower product purchase cost*
- *Fewer distress purchases*
- *Assured product supply*
- *Reduced daily management of inventory stocks & orders*
- *Automated ERP integration*
- *Extended e-business capability*

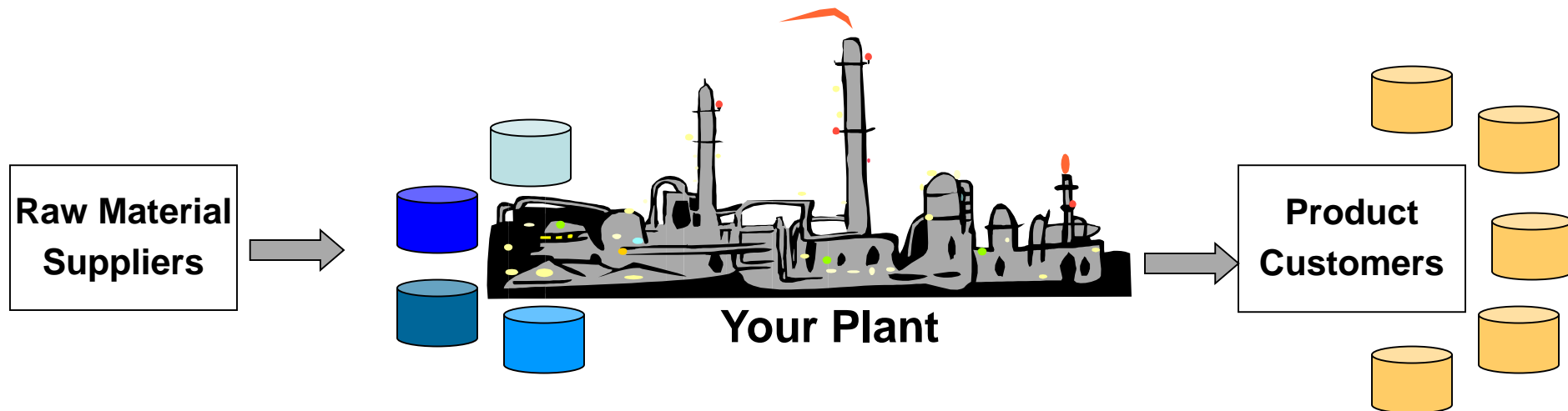

ProTRAQ VMI: The World Leader

VMI Benefits both Consumer & Vendor

Vendor Benefits

- *Reduced logistics cost*
- *Lower customer service cost*
- *Fewer consumer stock-outs*
- *Fewer unprofitable sales*
- *Improved cash cycle*
- *Automated ERP integration*
- *Increased customer loyalty*
- *New service opportunities*
- *Extended e-business capability*

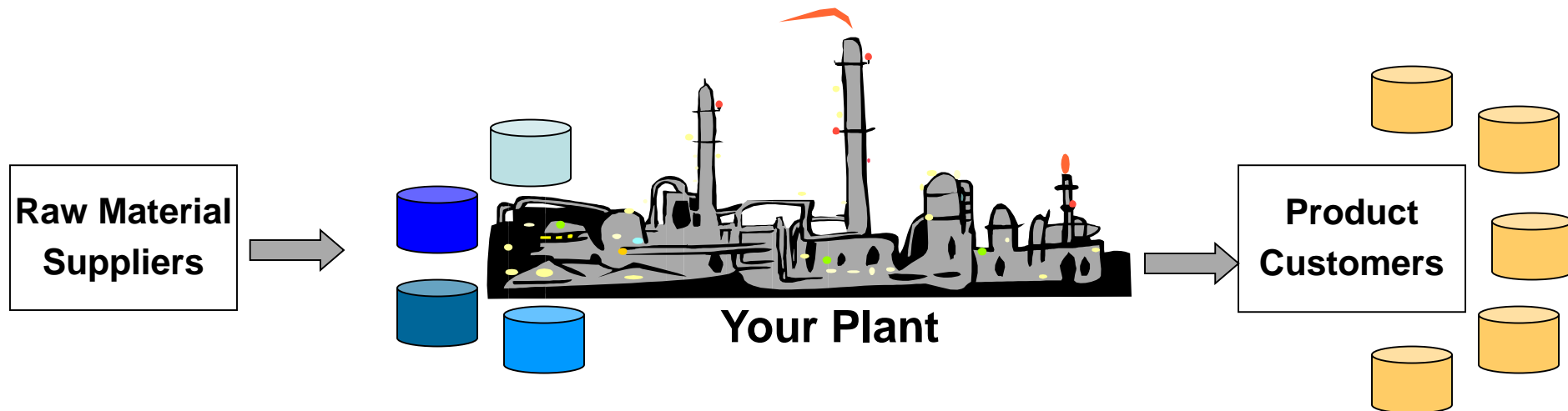

ProTRAQ VMI: The World Leader

The VMI Solution Set

1. *Field Data Collection*
2. *Data Hosting & ProTRAQ Calculations*
3. *Vendor/Consumer Interactions*
4. *Business System Integration (optional)*



ProTRAQ VMI: The World Leader

Field Data Collection – Inbound vs. Outbound

Inbound VMI

- *Inventory measurements are often already available in real-time database (PI)*
- *Can generally transfer data via VPN to central server for remote access by suppliers (vendors)*
- *New sensors installed as required and interfaced to site database or a Remote Monitoring Unit*

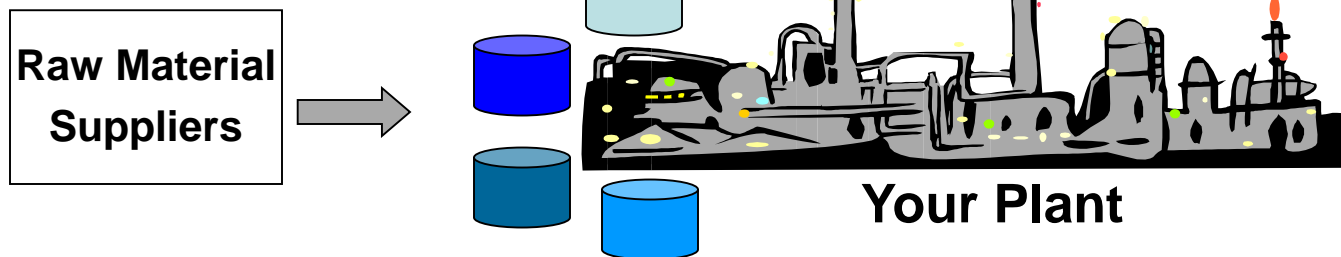

ProTRAQ VMI: The World Leader

Field Data Collection – Inbound vs. Outbound

Outbound VMI

- *Inventory measurements not usually available – no instrumentation installed*
- *Install level (or other) sensors and collect data with a telemetry device like a Remote Monitoring Unit*
- *Communication to central PI System for remote access via dial-up modem, wireless, cellular, etc.*

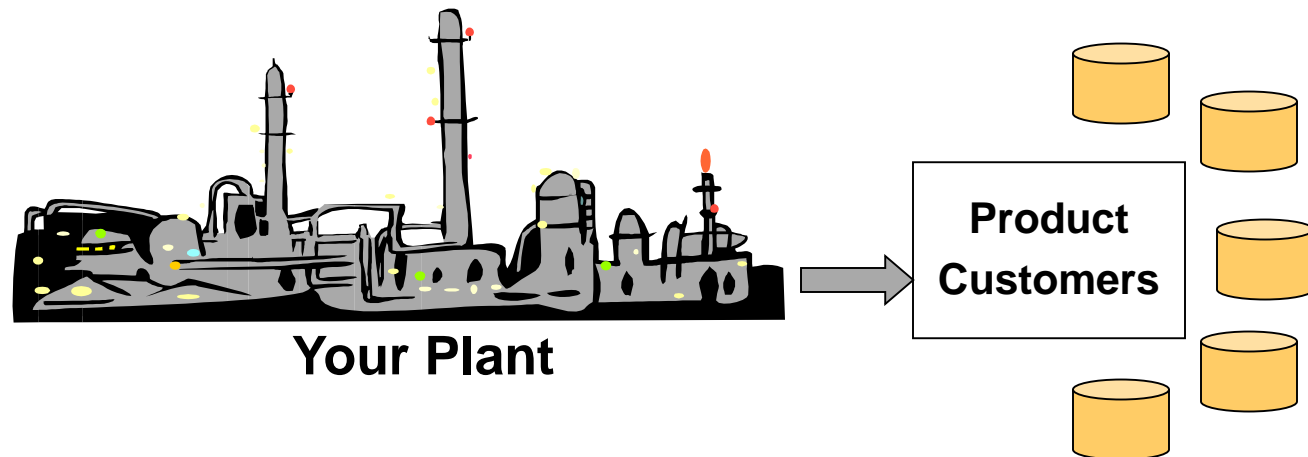

Field Data Collection - Sensors

- *Inventory measurement to fit local need*
 - *A variety of sensors can be used*
 - *Ultra-sonics, differential pressure, wave guided radar, flow meters, etc.*
 - *Different products have different needs*
 - *liquids, acids, polymers, plastics, powders, gases, etc.*
- *Picking the right sensor*
 - *ChemLogix experience and process helps*
 - *ChemLogix is neutral in regard to sensor type*



Field Data Collection – Typical Installation

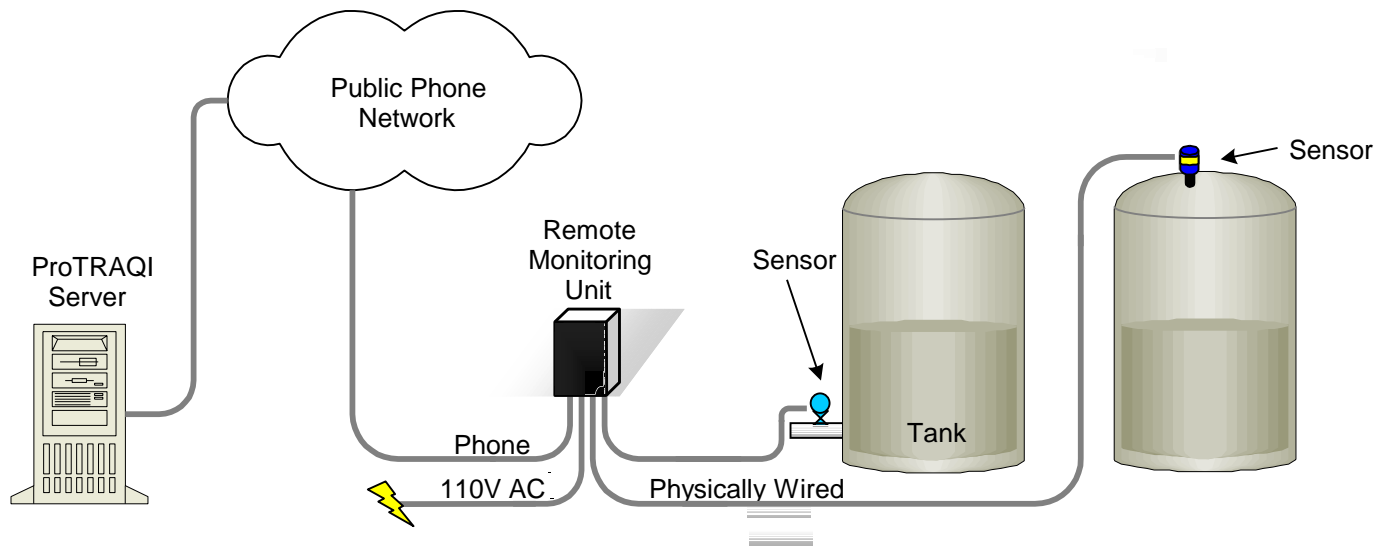

The ChemLogix RMU

- *1-199 analog inputs, standard is 8*
- *Works with any type of sensor / transmitter*
- *Local display and keypad interface*
- *Proactively set inventory alarms to central system*
- *Stores 1500+ periodic data logs in RAM per input*
- *Real-time readings available on demand via modem*

ProTRAQ VMI: The World Leader

Field Data Collection - Wireless Installation

Industrial Evolution

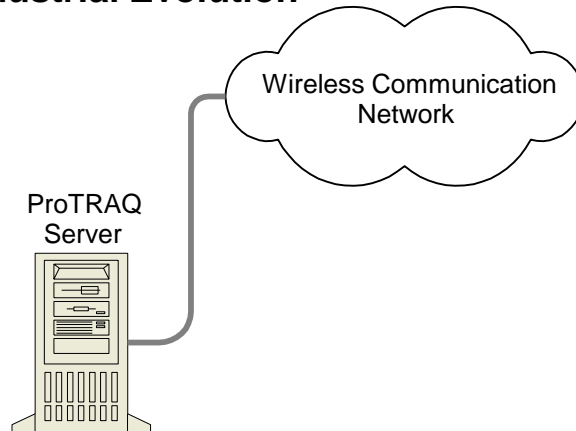

Inventory Location

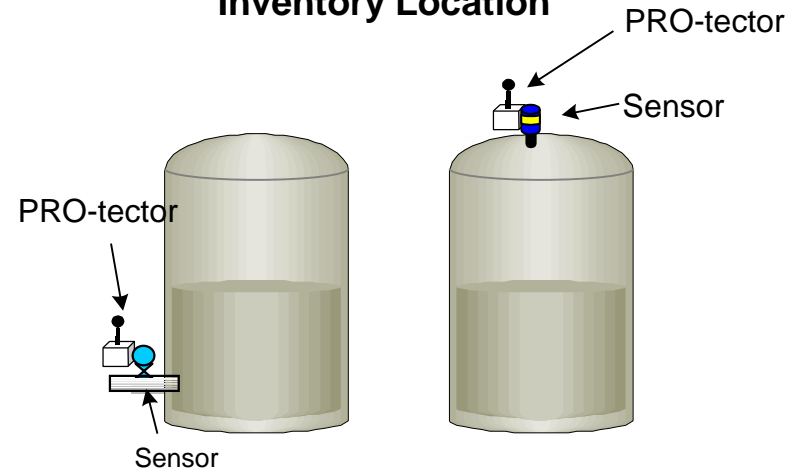

The ChemLogix PRO-tector®:

- *Monitors any 4-20mA sensor signals*
- *No (or minimal) wiring or conduit needed at the tank*
- *Self-contained, no distance limitations to overcome*
- *Typically broadcast the last 24 hours of readings, 2-4x/day*
- *Proactively alarms to central system – changeable remotely*
- *5-10 year battery life (lead acid with solar panel, or alkaline)*
- *Tanks can be mobile provided they stay within wireless range*

ProTRAQ VMI: The World Leader

Field Data Collection – Mini-PI System

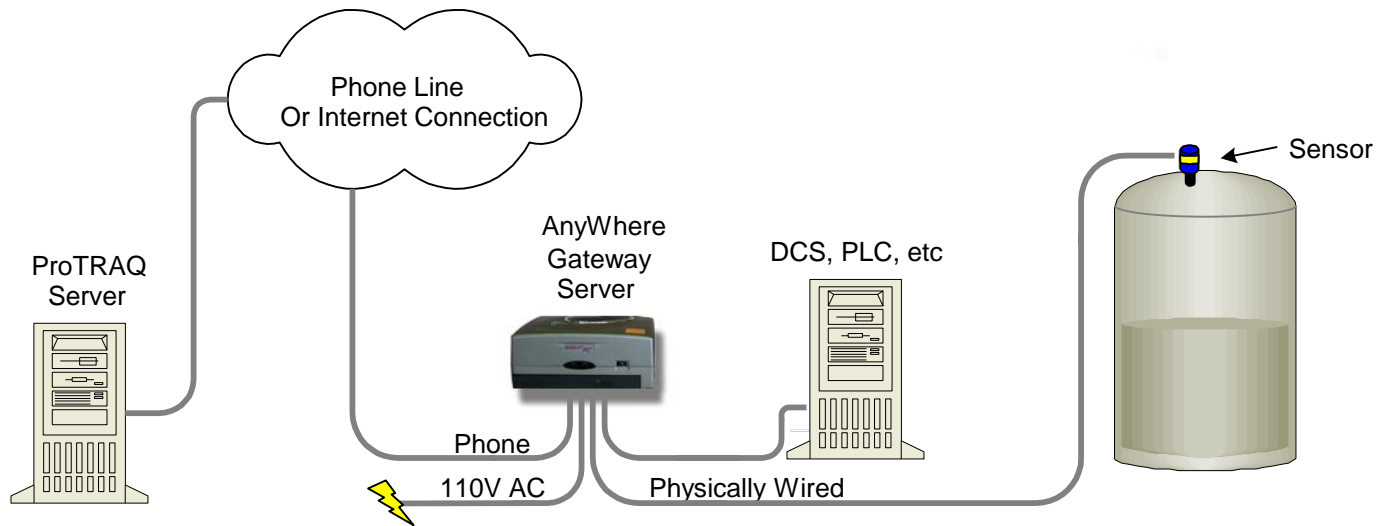

The AnyWhere Gateway:

- *Mini-PC with a PI System*
- *Over 350 device and system interfaces*
- *Remotely maintained; no local IT support required*
- *Communicates back over phone line or network*
- *Unlimited data collection capabilities*
- *Typically deployed in situations requiring inventories plus process measurements*

ProTRAQ VMI: The World Leader

Data Hosting & ProTRAQ Calculations

Data Storage in PI

- *Collected data stored in a central PI System*
- *Integrated with ProTRAQ calculations*

Data Viewing with ICE

- *Users access data with userID & password*
- *Users can see only their own data*
- *Data displayed in ICE web pages*

System Monitoring by Industrial Evolution

- *24/7 monitoring of complete solution, including data collection, hosting & ProTRAQ calculations*



Data Hosting & ProTRAQ Calculations

ProTRAQ is OS/soft's inventory package

- *Built in ACE*
- *Displayed in ICE*
- *Moving to .NET*

ProTRAQ I – Replenishment Forecasts

- *Real-time calculation of inventory usage rates*
- *Time-to-reorder, time-to-critical and time-to-empty calcs*

ProTRAQ II – Collaborative Reconciliation

- *Automatic detection of inventory receipts*
- *Detailed estimation of receipt volume(s)*

ProTRAQ III – Mobile Inventory Tracking

- *Manual entry of portable containers such as totes, drums, flexi-tanks, etc.*

ProTRAQ VMI: The World Leader

Vendor/Consumer Interactions

ICE for User Access

- *Access data from any Internet-connected device*
- *Mainly for Customer Service Agents (CSA's), but also available to others*

BuzzMe for e-Notification

- *Personalized alerts to email, pager, cellphone, PDA, etc*
- *Monitor inventory measurements or ProTRAQ calculations*

Inventory Reconciliation

- *Web pages support simultaneous access & review*
- *ProTRAQ has the “umpire” role*



Optional Business System Integration

RLINK Business Connector

- *Seamless integration to SAP & JDEdwards*
- *Bi-directional communications*
- *OSIsoft product!*

Supply chain integration

- *Automated transfer of inventory data*
- *Automated order generation*

Trading Exchange connections

- *Public & private hubs supported*
- *CIDX-compatible*

Optional Business System Integration

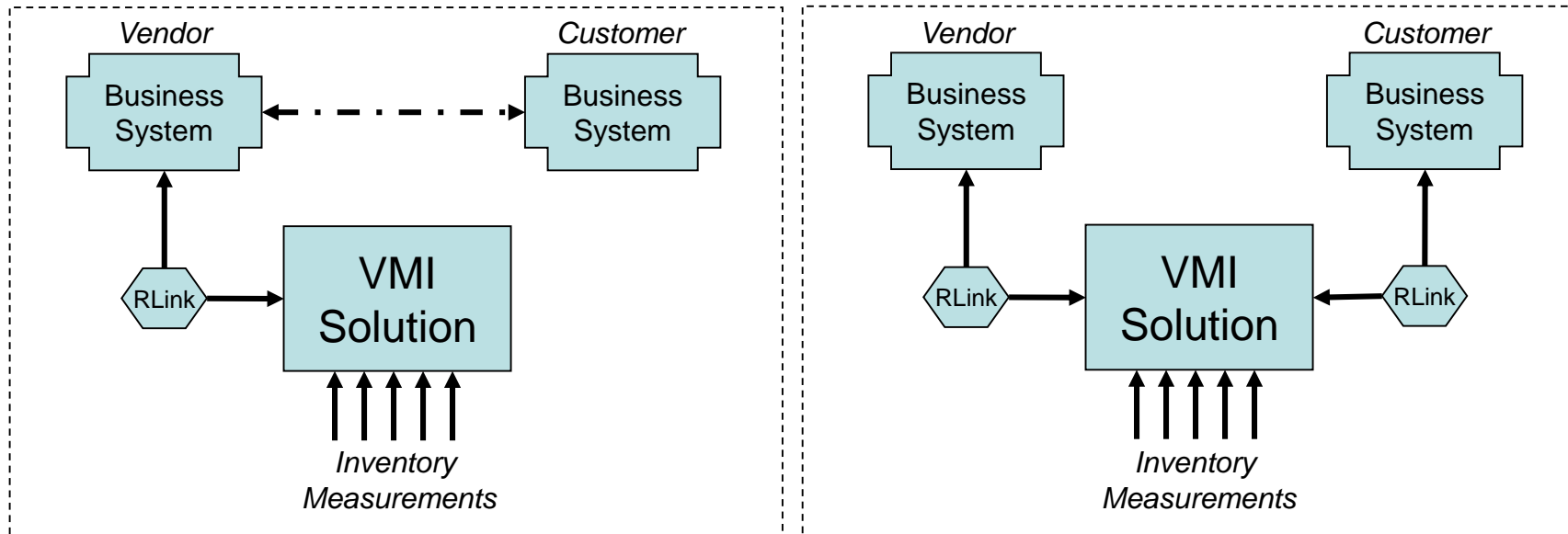

Integration points:

Customer information
BASF shipments
Stock-out prediction

Product information
Customer receipts

ProTRAQ VMI: The World Leader

The ProTRAQ VMI Solution

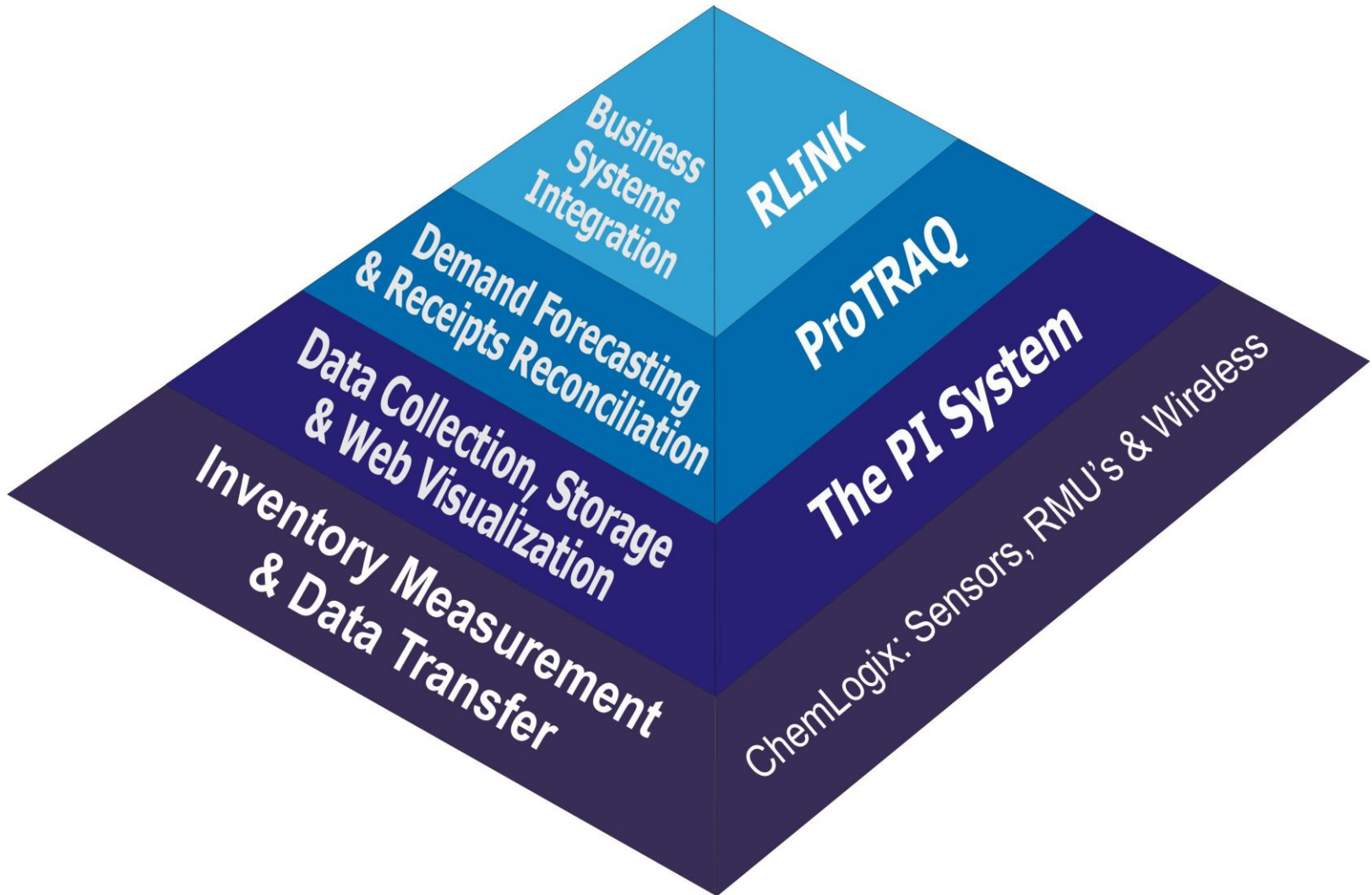

ProTRAQ VMI: The World Leader

Check Out ProTRAQ yourself!

- www.protraq.com shows the basics
- Also available for viewing on request:
 - Vessel configuration details
 - Alarm summary
 - Transfer report
 - Reconciliation pages
 - BuzzMe e-mail/pager notification
- For more details or additional display access contact either ChemLogix or Industrial Evolution

Go to "www.protraq.com"

Shared Inventory Management Service



...featuring the ProTRAQ software from OSIssoft and secure hosting services by Industrial Evolution



Existing customers: [Login here](#)

First-Time Users: [Click here](#)

Click one of these buttons to log in to the ProTRAQ web server

Want to learn more about our Shared Inventory Management Service? Select any of the following links:

[ProTRAQ Overview](#)

[3-layer Architecture](#)

Or, to learn more about [OSIssoft](#) or [Industrial Evolution](#), visit our websites by clicking on the logos or company names above.

Shared Inventory Management Service



...featuring the ProTRAQ software from OSIssoft and secure hosting services by Industrial Evolution



Existing customers: [Login here](#)

Want to let the following

Or, to learn the logos

Enter Network Password

Please type your user name and password.

Site: ice.protraq.com

User Name:

Password:

Domain:

Save this password in your password list

OK Cancel

Enter "protraq" as the User Name, [If you are running XP, enter "protraq\protraq"]

enter "demo" as the Password,

and enter "protraq" as the Domain Name

After entering the required information, click OK



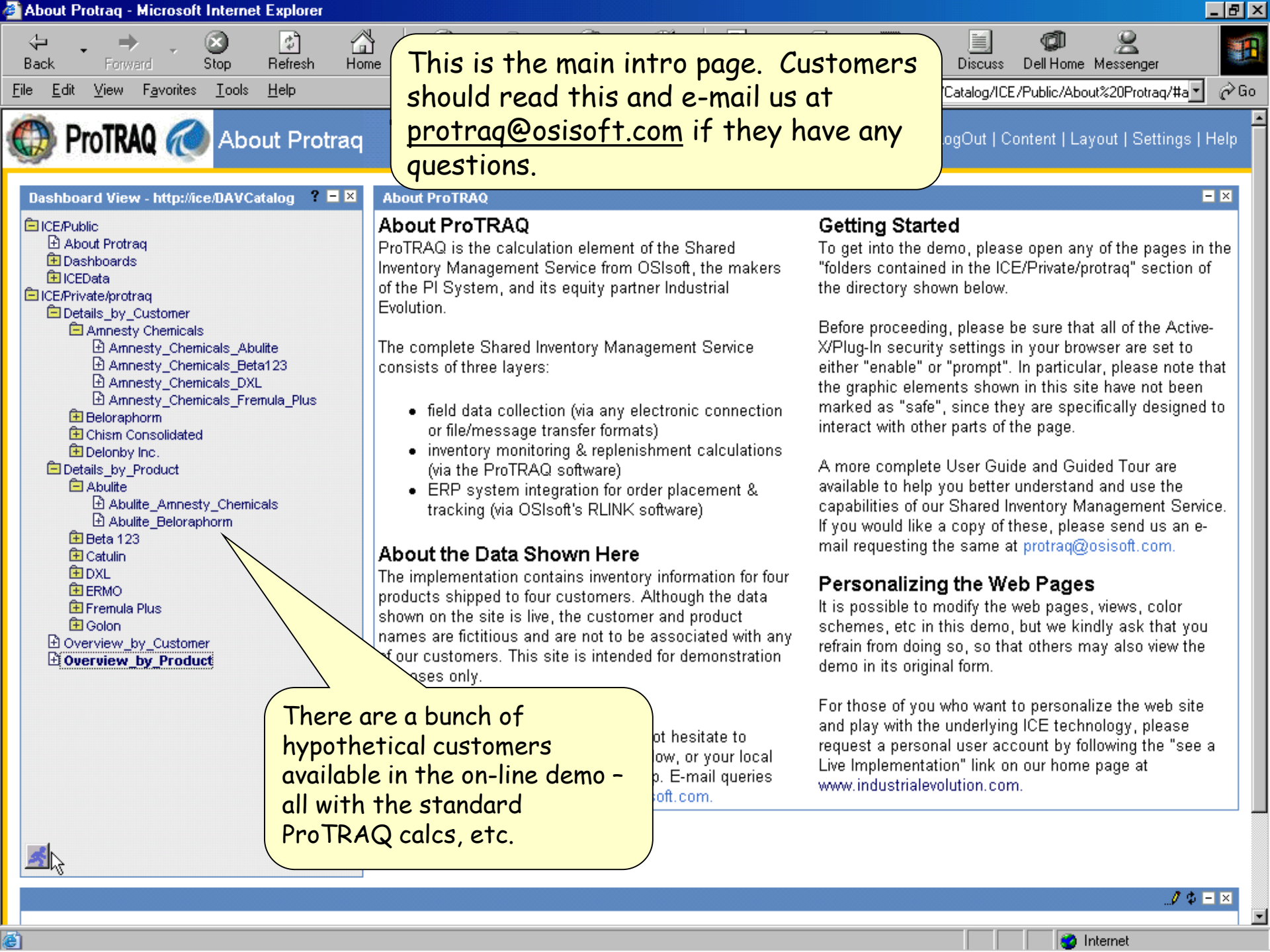

This is the main intro page. Customers should read this and e-mail us at protraq@osisoft.com if they have any questions.

- Dashboard View - http://ice/DAVCatalog ?
- ICE/Public
 - About Protraq
 - Dashboards
 - ICEData
- ICE/Private/protraq
 - Details_by_Customer
 - Amnesty Chemicals
 - Amnesty_Chemicals_Abulite
 - Amnesty_Chemicals_Beta123
 - Amnesty_Chemicals_DXL
 - Amnesty_Chemicals_Fremula_Plus
 - Beloraphorm
 - Chism Consolidated
 - Delonby Inc.
 - Details_by_Product
 - Abulite
 - Abulite_Amnesty_Chemicals
 - Abulite_Beloraphorm
 - Beta 123
 - Catulin
 - DXL
 - ERMO
 - Fremula Plus
 - Golon
 - Overview_by_Customer
 - Overview_by_Product**

About ProTRAQ

ProTRAQ is the calculation element of the Shared Inventory Management Service from OSIssoft, the makers of the PI System, and its equity partner Industrial Evolution.

The complete Shared Inventory Management Service consists of three layers:

- field data collection (via any electronic connection or file/message transfer formats)
- inventory monitoring & replenishment calculations (via the ProTRAQ software)
- ERP system integration for order placement & tracking (via OSIssoft's RLINK software)

About the Data Shown Here

The implementation contains inventory information for four products shipped to four customers. Although the data shown on the site is live, the customer and product names are fictitious and are not to be associated with any of our customers. This site is intended for demonstration purposes only.

There are a bunch of hypothetical customers available in the on-line demo - all with the standard ProTRAQ calcs, etc.

Getting Started

To get into the demo, please open any of the pages in the "folders contained in the ICE/Private/protraq" section of the directory shown below.

Before proceeding, please be sure that all of the Active-X/Plug-In security settings in your browser are set to either "enable" or "prompt". In particular, please note that the graphic elements shown in this site have not been marked as "safe", since they are specifically designed to interact with other parts of the page.

A more complete User Guide and Guided Tour are available to help you better understand and use the capabilities of our Shared Inventory Management Service. If you would like a copy of these, please send us an e-mail requesting the same at protraq@osisoft.com.

Personalizing the Web Pages

It is possible to modify the web pages, views, color schemes, etc in this demo, but we kindly ask that you refrain from doing so, so that others may also view the demo in its original form.

For those of you who want to personalize the web site and play with the underlying ICE technology, please request a personal user account by following the "see a Live Implementation" link on our home page at www.industrialevolution.com.

not hesitate to
low, or your local
p. E-mail queries
soft.com.

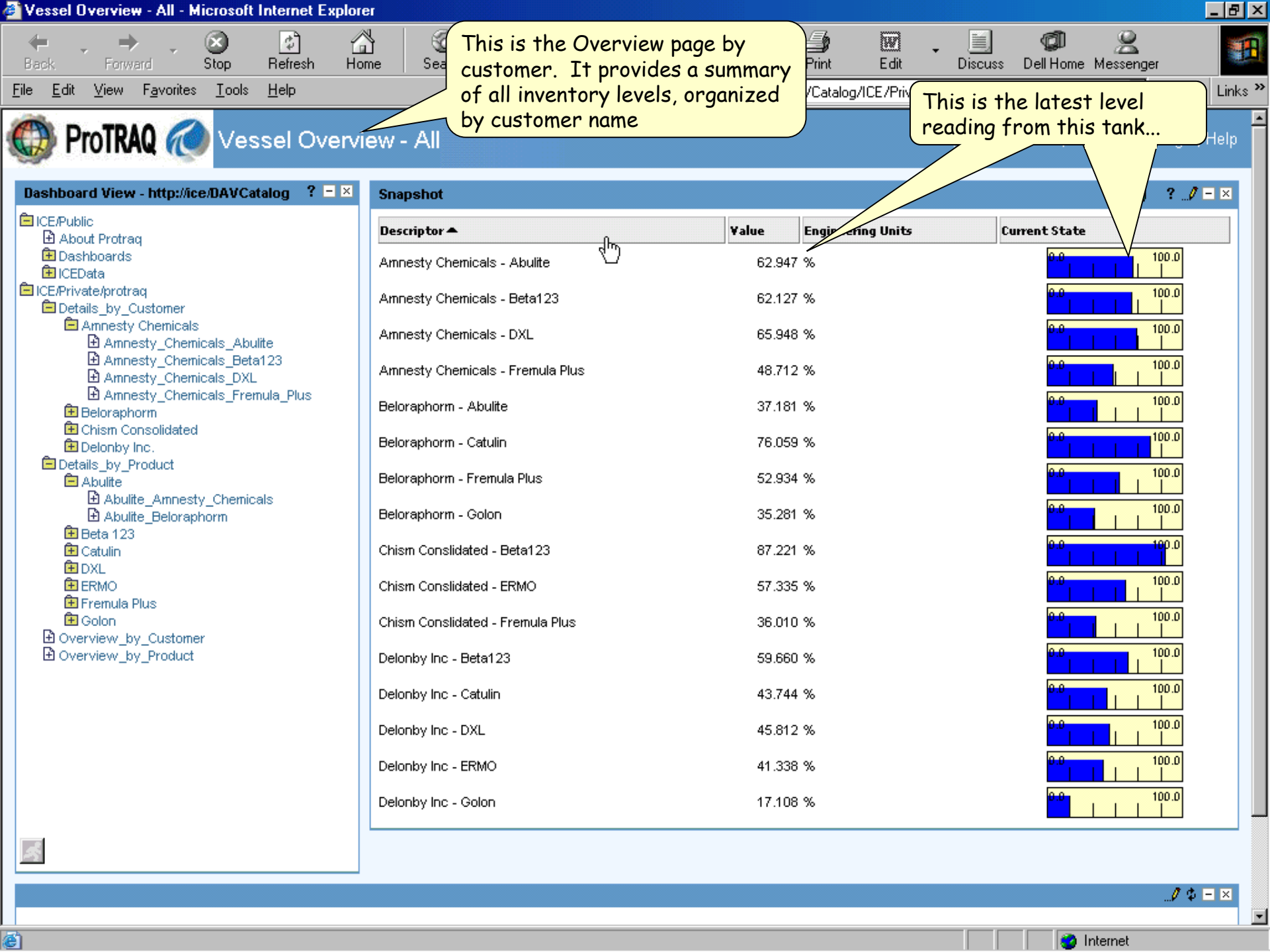

This is the Overview page by customer. It provides a summary of all inventory levels, organized by customer name

This is the latest level reading from this tank...

Dashboard View - http://ice/DAVCatalog ?

- ICE/Public
 - About Protraq
 - Dashboards
 - ICEData
- ICE/Private/protraq
 - Details_by_Customer
 - Amnesty Chemicals
 - Amnesty_Chemicals_Abulite
 - Amnesty_Chemicals_Beta123
 - Amnesty_Chemicals_DXL
 - Amnesty_Chemicals_Fremula_Plus
 - Beloraphorm
 - Chism Consolidated
 - Delonby Inc.
 - Details_by_Product
 - Abulite
 - Abulite_Amnesty_Chemicals
 - Abulite_Beloraphorm
 - Beta 123
 - Catulin
 - DXL
 - ERMO
 - Fremula Plus
 - Golon
 - Overview_by_Customer
 - Overview_by_Product

Snapshot

Descriptor	Value	Engineering Units	Current State
Amnesty Chemicals - Abulite	62.947 %		
Amnesty Chemicals - Beta123	62.127 %		
Amnesty Chemicals - DXL	65.948 %		
Amnesty Chemicals - Fremula Plus	48.712 %		
Beloraphorm - Abulite	37.181 %		
Beloraphorm - Catulin	76.059 %		
Beloraphorm - Fremula Plus	52.934 %		
Beloraphorm - Golon	35.281 %		
Chism Consolidated - Beta123	87.221 %		
Chism Consolidated - ERMO	57.335 %		
Chism Consolidated - Fremula Plus	36.010 %		
Delonby Inc - Beta123	59.660 %		
Delonby Inc - Catulin	43.744 %		
Delonby Inc - DXL	45.812 %		
Delonby Inc - ERMO	41.338 %		
Delonby Inc - Golon	17.108 %		



Ad Hoc trends etc all work here, but the personalization features are disabled - check out the standard IE demo to show off those parts of ICE

Click here to organize the inventories by level

Dashboard View - http://ice/DAVCatalog

- ICE/Public
 - About Protraq
 - Dashboards
 - ICEData
- ICE/Private/protraq
 - Details_by_Customer
 - Amnesty Chemicals
 - Amnesty_Chemicals_Abulite
 - Amnesty_Chemicals_Beta123

	Value	Engineering Units	Current State
	17.108 %		
norm - Golon	35.281 %		
ism Consolidated - Fremula Plus	36.010 %		

\\172.16.1.26\Protraq_501E.LEV - Microsoft Internet Explorer

ProTRAQ Start: *-5d End: * Apply

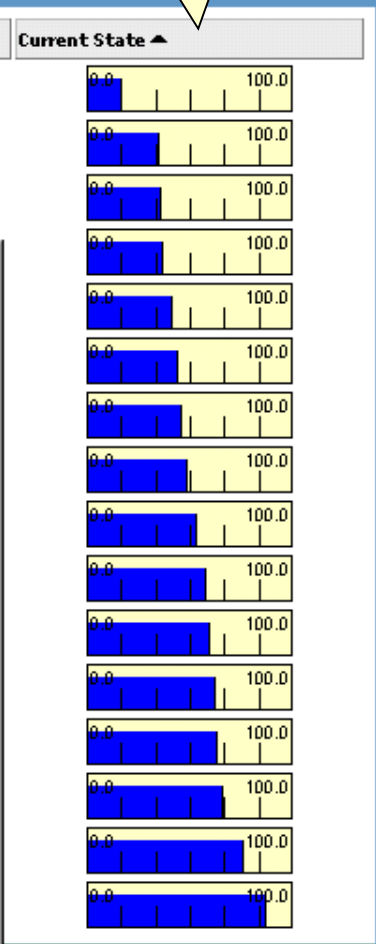
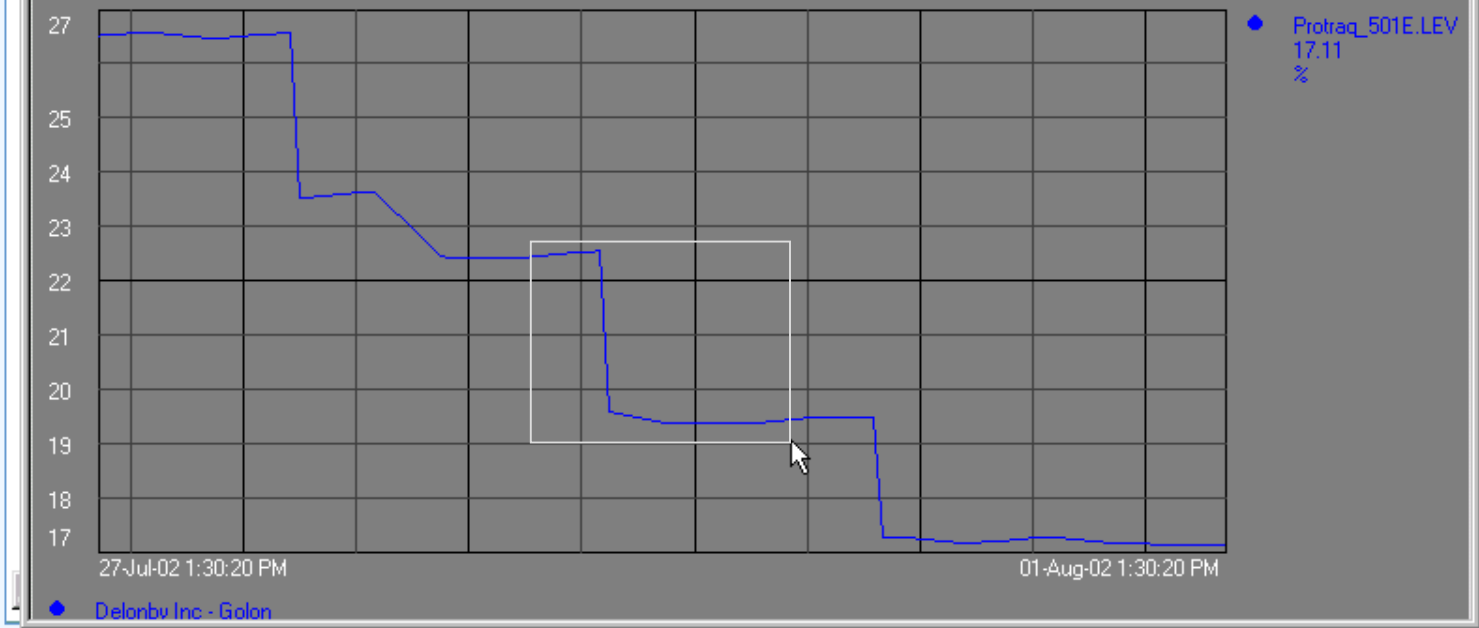

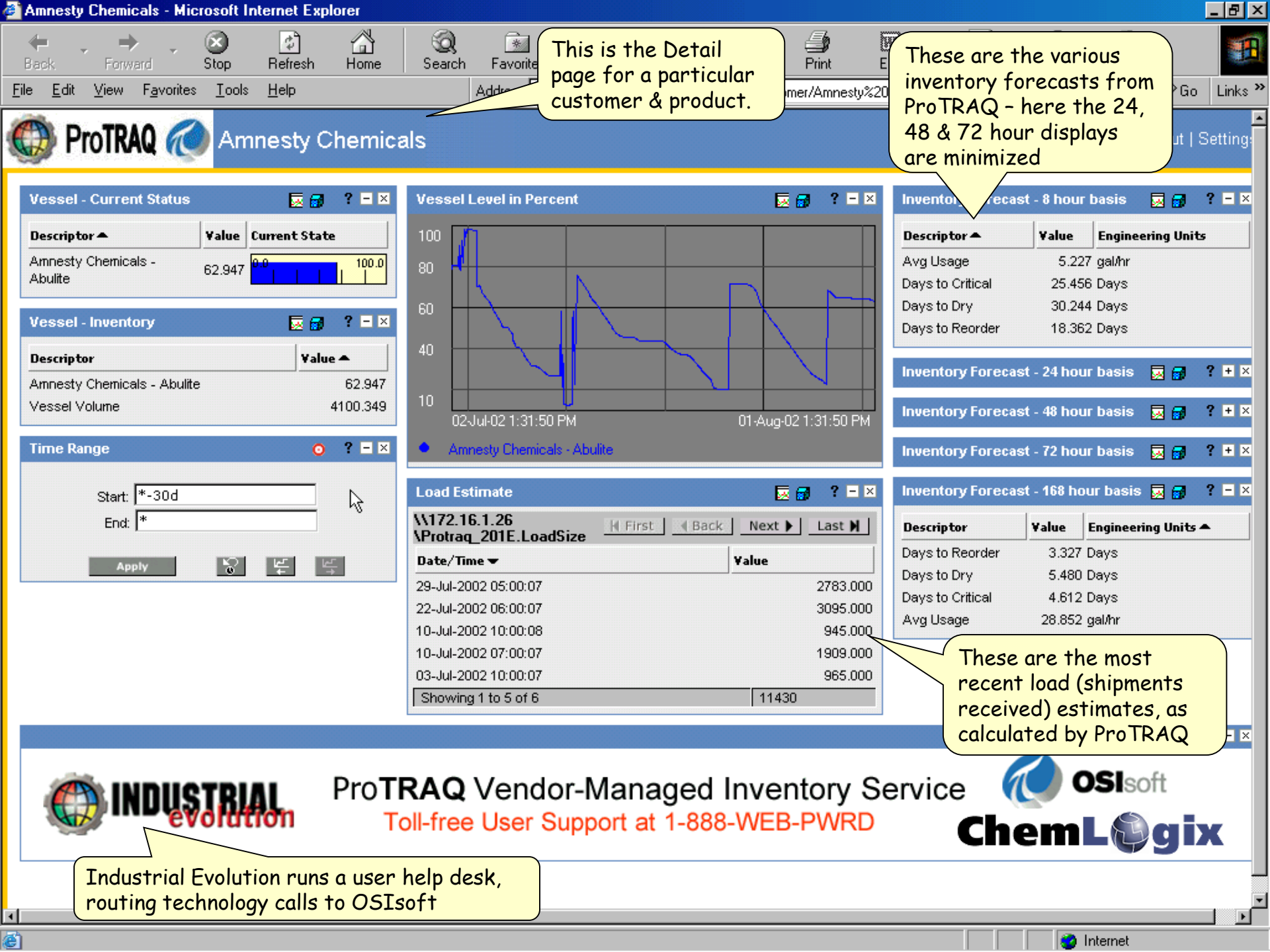

This is the Detail page for a particular customer & product.

These are the various inventory forecasts from ProTRAQ - here the 24, 48 & 72 hour displays are minimized

Vessel - Current Status

Descriptor	Value	Current State
Amnesty Chemicals - Abulite	62.947	0.0

Vessel - Inventory

Descriptor	Value
Amnesty Chemicals - Abulite	62.947
Vessel Volume	4100.349

Time Range

Start: *-30d
End: *

Apply

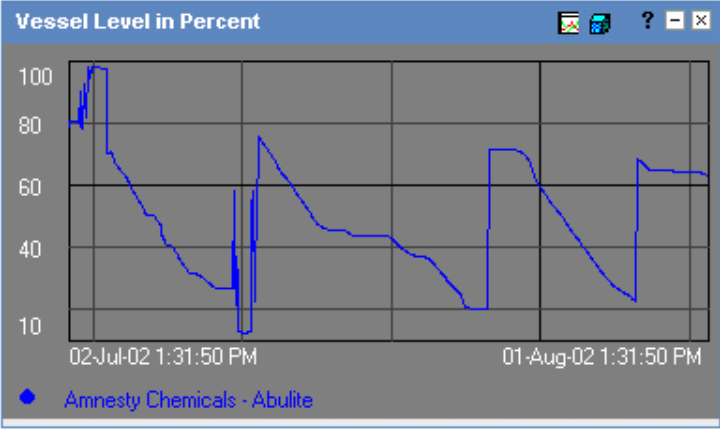

Load Estimate

\\172.16.1.26
\\Protraq_201E.LoadSize

Date/Time	Value
29-Jul-2002 05:00:07	2783.000
22-Jul-2002 06:00:07	3095.000
10-Jul-2002 10:00:08	945.000
10-Jul-2002 07:00:07	1909.000
03-Jul-2002 10:00:07	965.000
Showing 1 to 5 of 6	11430

Inventory Forecast - 8 hour basis

Descriptor	Value	Engineering Units
Avg Usage	5.227	gal/hr
Days to Critical	25.456	Days
Days to Dry	30.244	Days
Days to Reorder	18.362	Days

Inventory Forecast - 24 hour basis

Inventory Forecast - 48 hour basis

Inventory Forecast - 72 hour basis

Inventory Forecast - 168 hour basis

Descriptor	Value	Engineering Units
Days to Reorder	3.327	Days
Days to Dry	5.480	Days
Days to Critical	4.612	Days
Avg Usage	28.852	gal/hr

These are the most recent load (shipments received) estimates, as calculated by ProTRAQ



ProTRAQ Vendor-Managed Inventory Service
Toll-free User Support at 1-888-WEB-PWRD



Industrial Evolution runs a user help desk, routing technology calls to OSIsoft

BASF Case Study

- *BASF sells specialty products (dispersants)*
 - *Products are used to make paint, carpet backing, paper, adhesives and sealants*
- *Customers often required “rush” shipments due to lack of planning*
 - *Extra shipping & production costs incurred by BASF*
 - *No extra margin due to threat of competitive supply and short term contracts*
- *With ProTRAQ, BASF takes responsibility for inventory management*

BASF Case Study

- *BASF benefits*
 - *Improved customer satisfaction*
 - *Fewer transaction errors*
 - *Reduction of inventory*
 - *Reduced administrative costs*
 - *Increased return on capital*
 - *Improved efficiency for supplier & buyer*

BASF Case Study

- Biggest benefit to BASF:
 - ability to secure longer-term customer contracts
 - pro-actively optimization of inventory production and shipments
- Biggest consumer benefit:
 - Lower cost
 - More reliable supply

BASF Project Progress

- *Implementations include the following BASF customers in Mexico:*



- *All BASF customer projects include:*
 - *Data collection & communication hardware installation at customer site*
 - *ProTRAQ inventory management calcs*
 - *Web access from any PC*
- *Additional customer sites are being rolled out*
- *RLINK connection back to BASF SAP system planned as part of the VMI service*



Other Customers

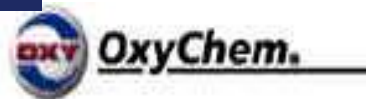

BESTFOODS



ProTRAQ VMI: The World Leader



2003
OSISOFT USERS CONFERENCE

RTMPM

True collaboration is only realized when there is “one version of the truth”

Contacts:

Gene Sullivan @ ChemLogix – (630) 775-7583

Simon Wright @ Industrial Evolution – (602) 867-0416

Or your favorite OSISOFT salesperson!

BASF Case Study

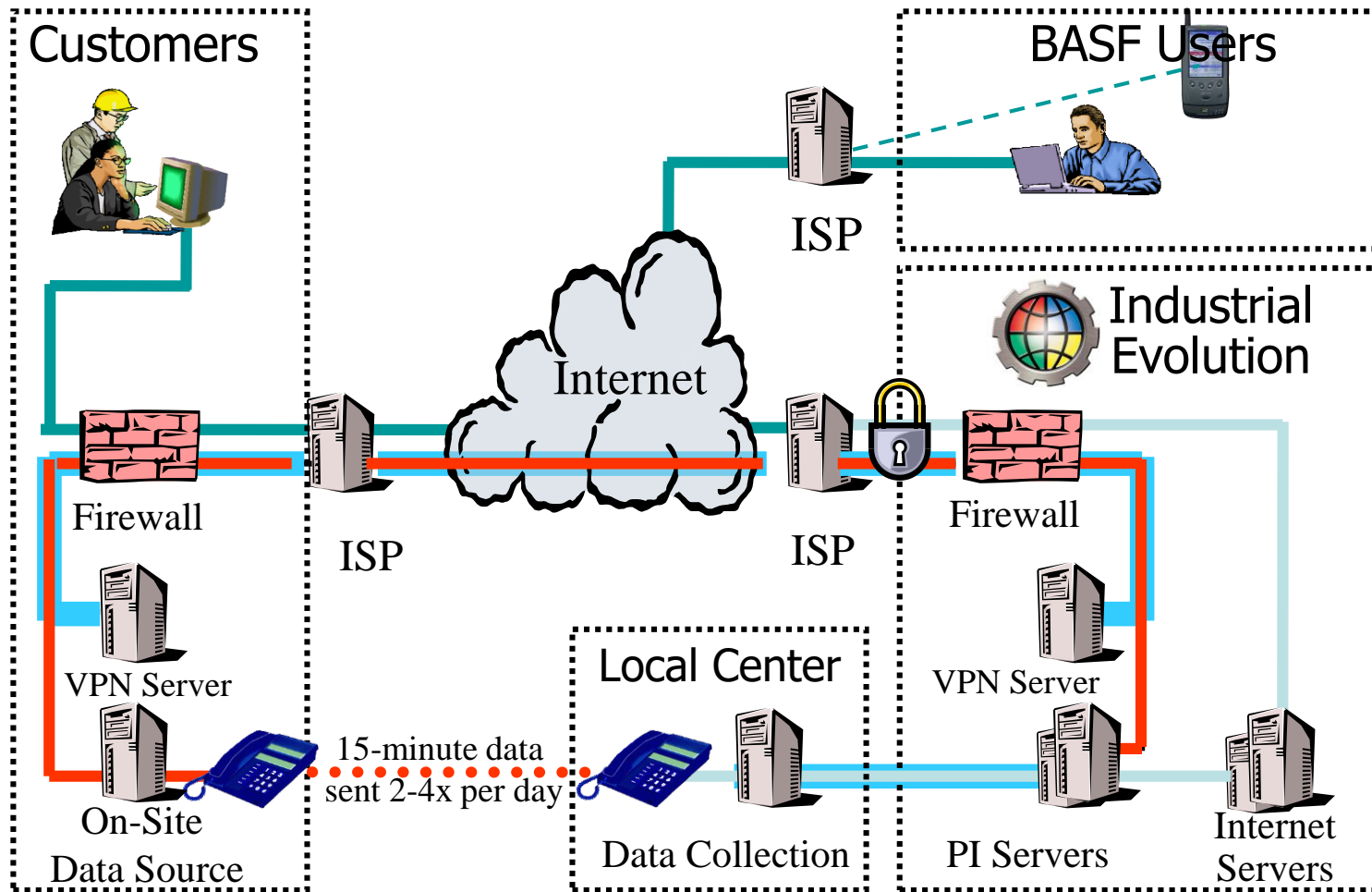

ProTRAQ VMI: The World Leader