

NOVEMBER 16, 2022

---

# Optimizing Refinery Operations

A Digital Transformation Journey

Presented by: Doug Raven, Saudi Aramco

aramco



## Saudi Aramco

### Real-Time Operations Digital Transformation

- 1990's: Corporate-wide Real-Time Infrastructure  
[AVEVA PI System]
- 2000's: Advanced Process Control (APC) Deployment
- 2010's: Performance Monitoring and Benchmarking
- 2020's: Closed-Loop Real-Time Optimization (RTO) & Process Digital Twin (PDT) Deployment

# Optimizing Refinery Operations

aramco

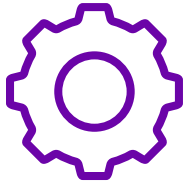

## Challenge

- Close the **Plan vs Actual** performance gap for a refinery providing transportation fuels for western Saudi Arabia
- Close the **Technology Gap** between the Refinery Planning System and APC System



## Solution

- Deployed a **refinery-wide** optimization solution utilizing **AVEVA Process Optimization** software on a **PI System** infrastructure to provide real-time optimum operating targets for all key process parameters.

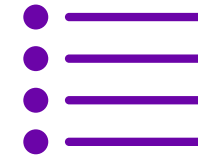

## Benefits

- **Continuously maximizes** most-valuable refinery products while maintaining product specifications and adhering to process constraints
- Payback time: **3-6 months**

# Refinery Operations Challenge

## Operations Technology Gap

- No systematic connection between Planning/Scheduling and APC
- **Monthly Planning LP:** Provides monthly optimal, average operation plan for the enterprise
- **Daily/Weekly Schedule:** Provides operation orders for site based on plan
- **Advanced Process Control:** Stabilizes unit operation based on manually entered targets

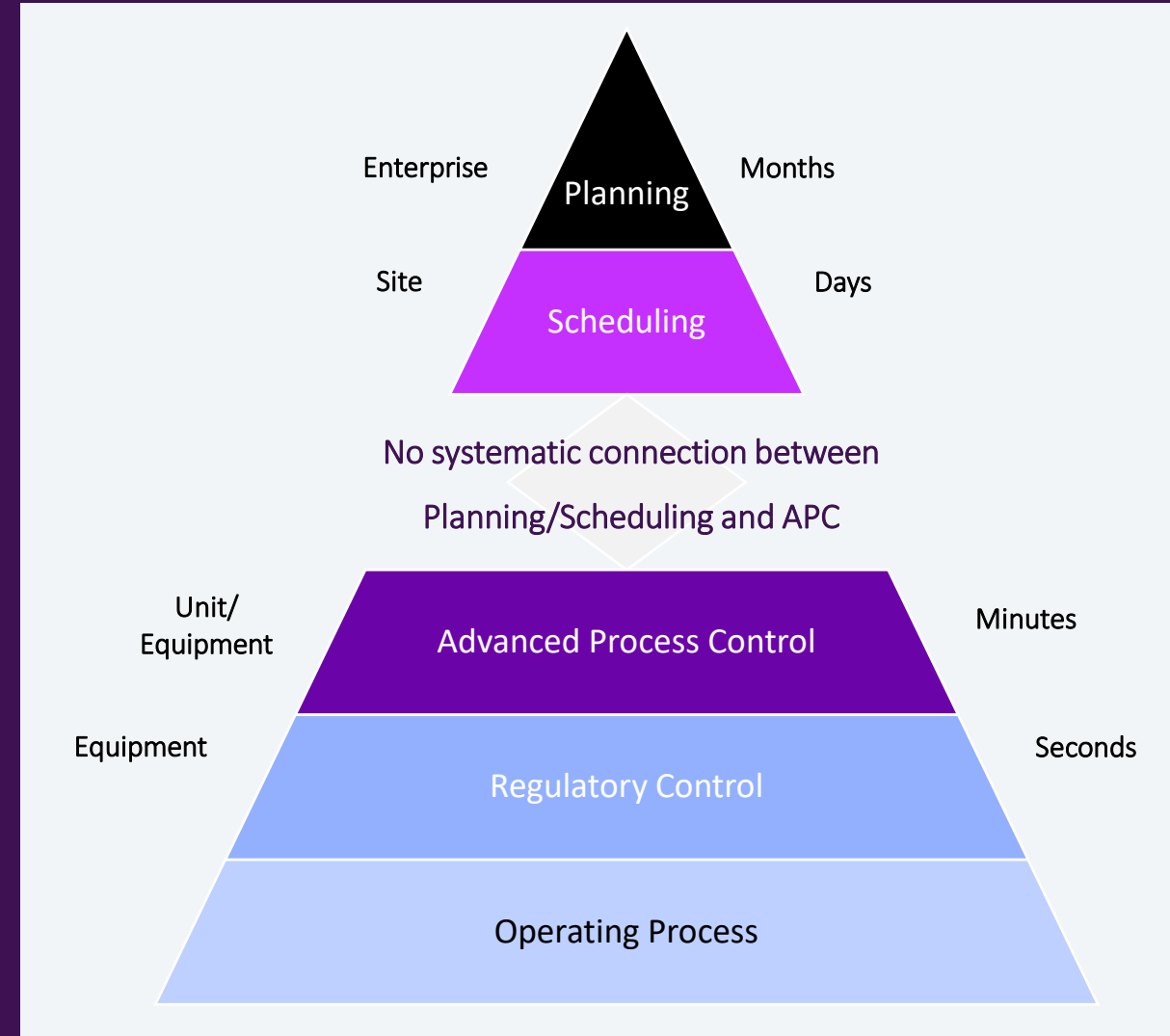

# Refinery Operations Challenge

## Technology Gap Causes Performance Gap

- **Misalignment** between planning, scheduling and APC objectives, constraints and targets.
- **Simplification** in planning and scheduling models.
- **Infrequent** feedback from actual process conditions.
- Process constraints **unaccounted** for in real-time.
- **Manual communication** of coordinating information
- **Plan vs. Actual Gap: up to 10% of crude margin**

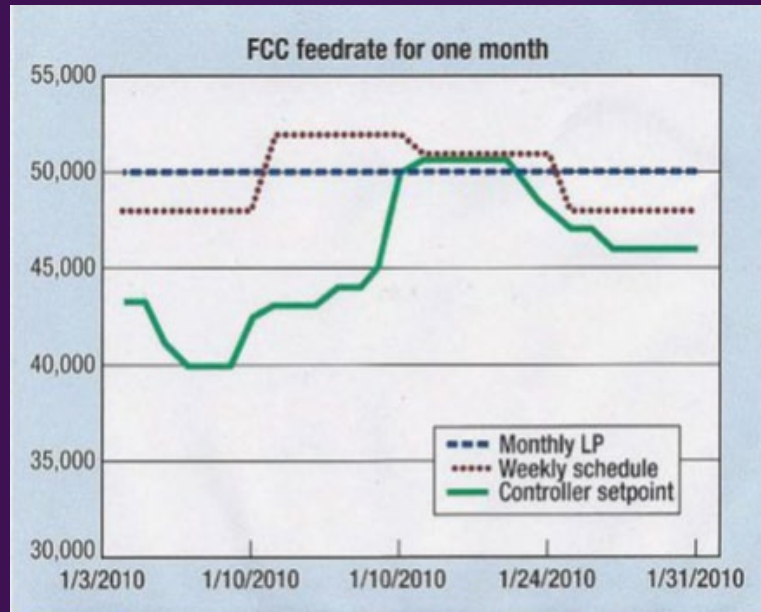

# Refinery-wide RTO Solution

## What is RTO?

*A scope-wide rigorous or semi-rigorous nonlinear process model utilized directly or through steady-state gain updates by a scope-wide economic optimization calculation implemented in a closed-loop manner.*

- Economics, current operating constraints (APC/DCS), Operating Plan, and Lab Results are fed to RTO
- RTO calculates optimum operating scenario using rigorous process models updated with real-time data
- RTO automatically adjusts refinery parameters using existing APC and DCS infrastructure

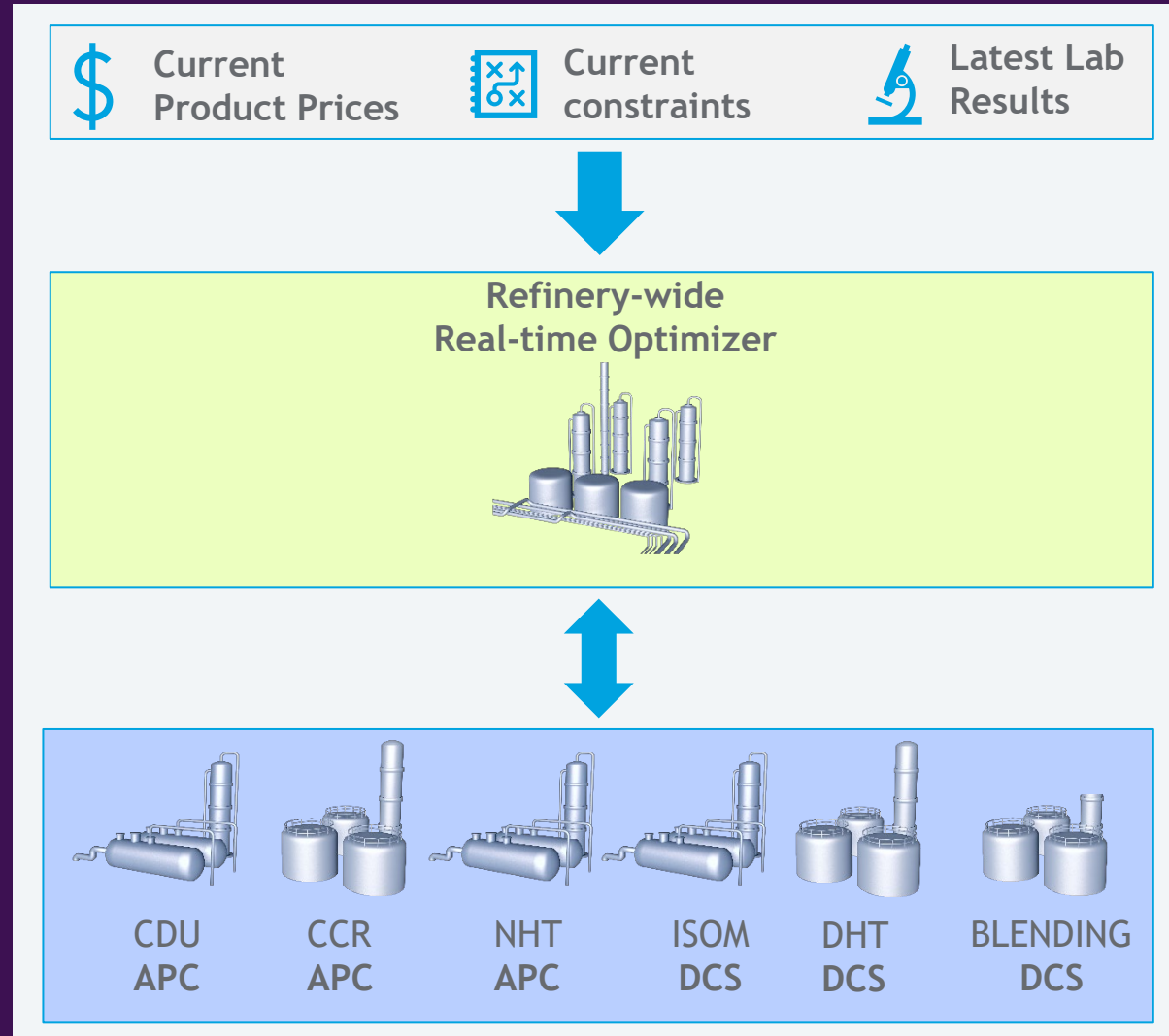

# Refinery-wide RTO Solution

## AVEVA Process Optimization on PI System Infrastructure

- Aligns and coordinates planning, scheduling and APC systems
- Utilizes rigorous process models
- Continuously fits models to actual process conditions

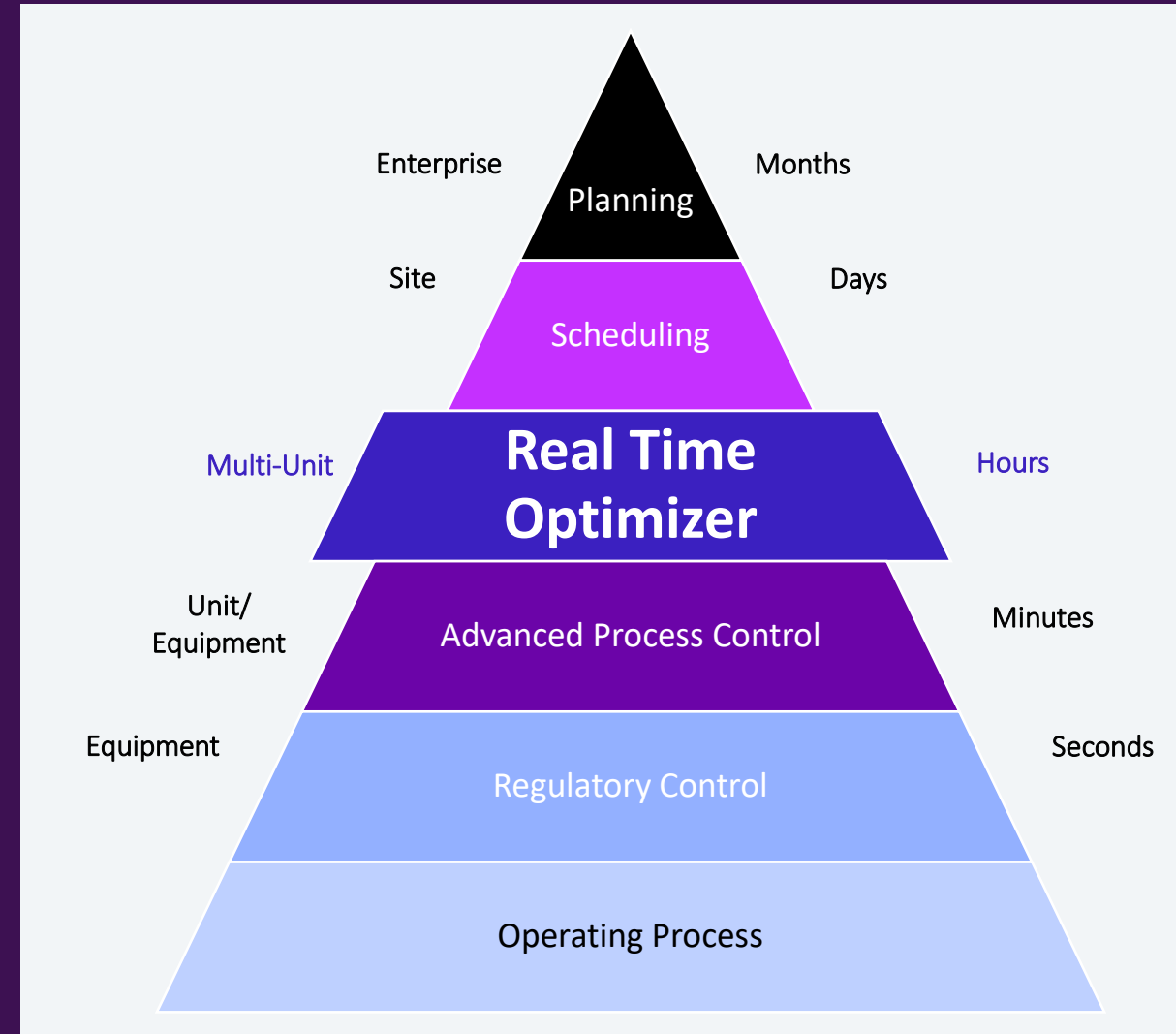



# Refinery-wide RTO Solution

## AVEVA Process Optimization on PI System Infrastructure

- Accounts for real-time **process constraints**
- Optimizes APC targets while achieving schedule and plan objectives
- **Closes Plan vs. Actual Gap**
- Also finds **new paths** to achieve plan in better ways

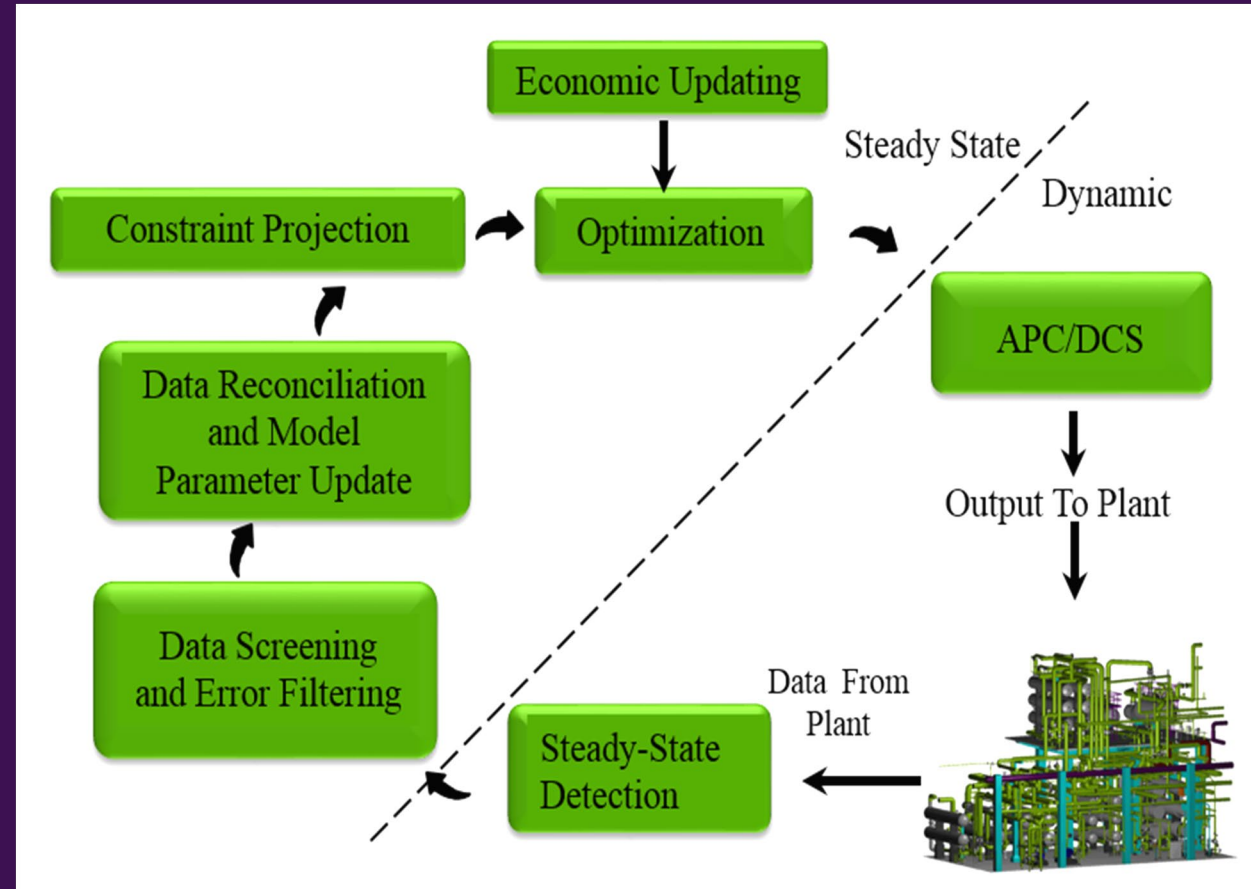



# AVEVA Process Optimization on PI System Infrastructure

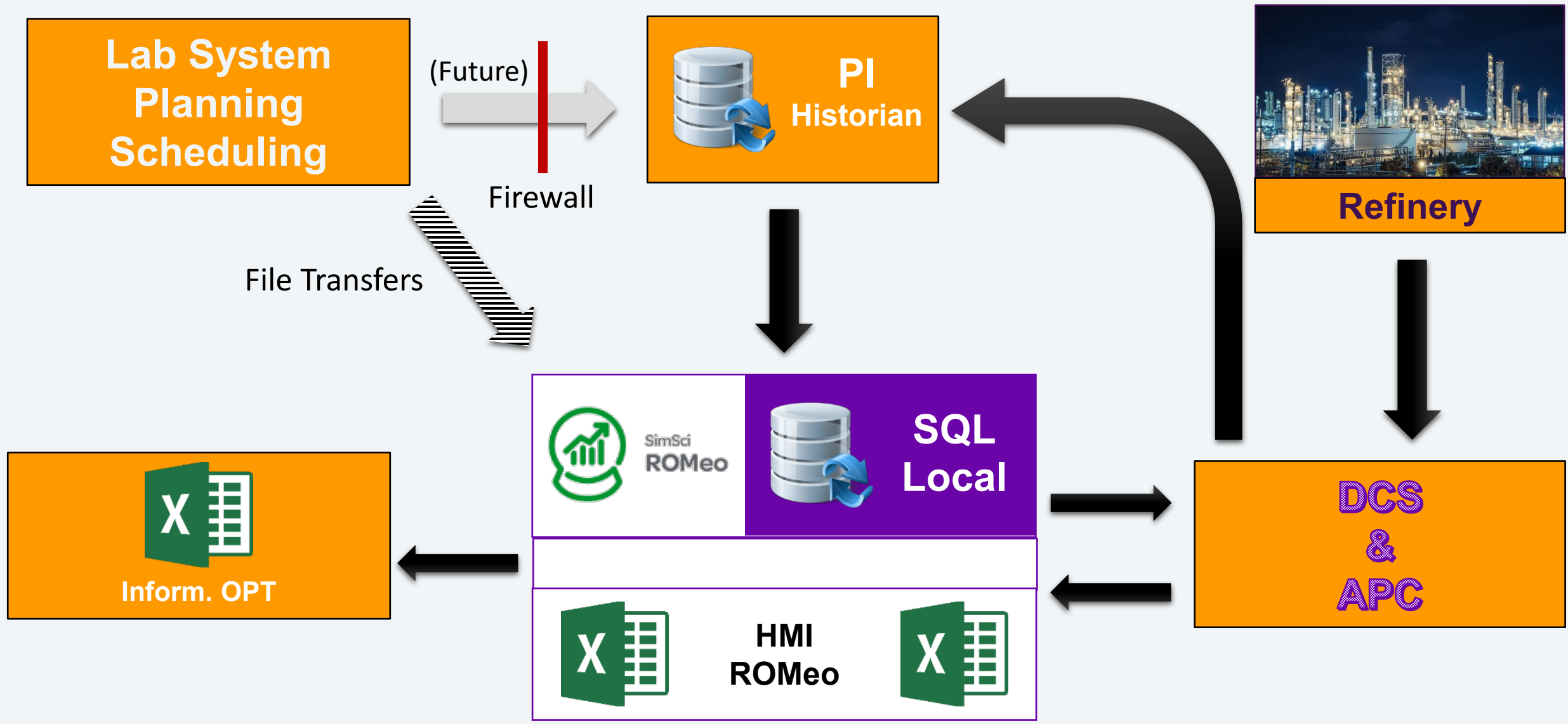

# Implementation Challenges

- Very aggressive **7-month** project schedule
- **Refinery-wide** scope of solution
- Changing refinery operation modes
- Delays in computing infrastructure
- **Cyber-security** restrictions
- Pandemic travel restrictions

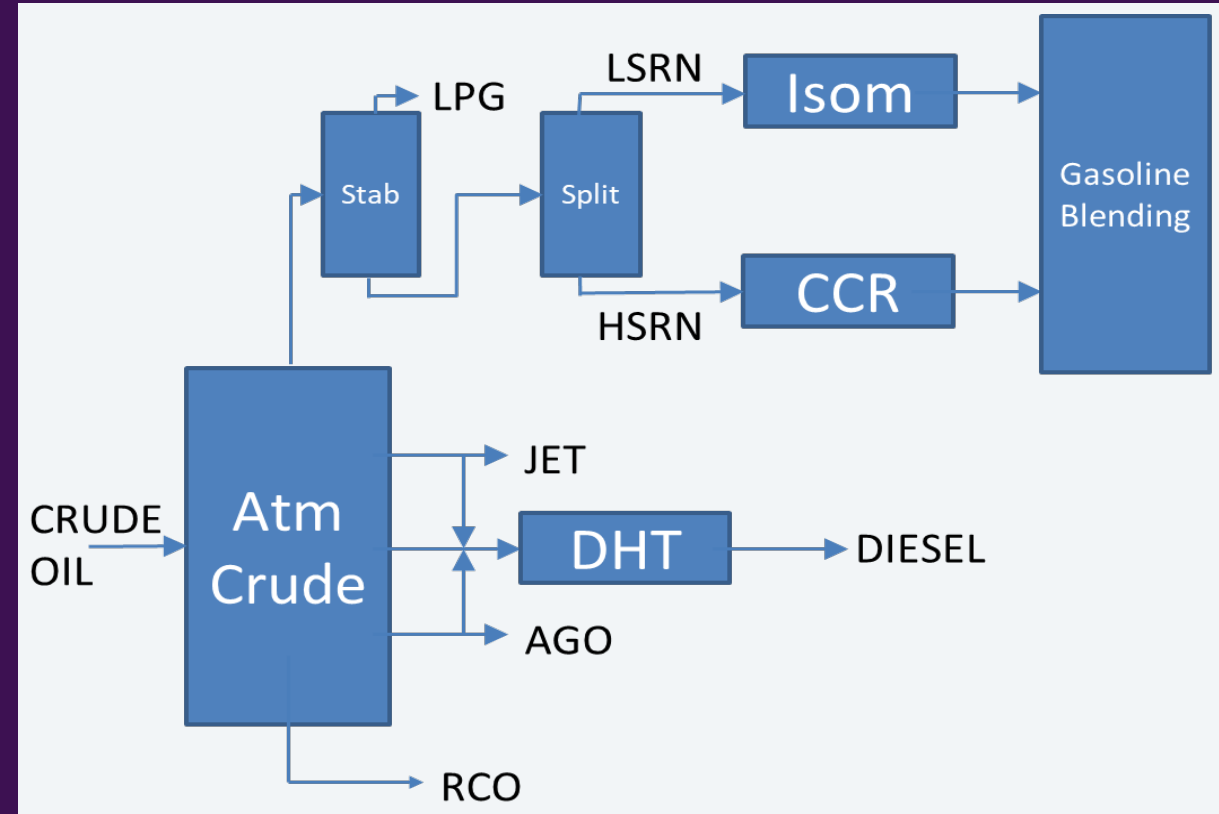

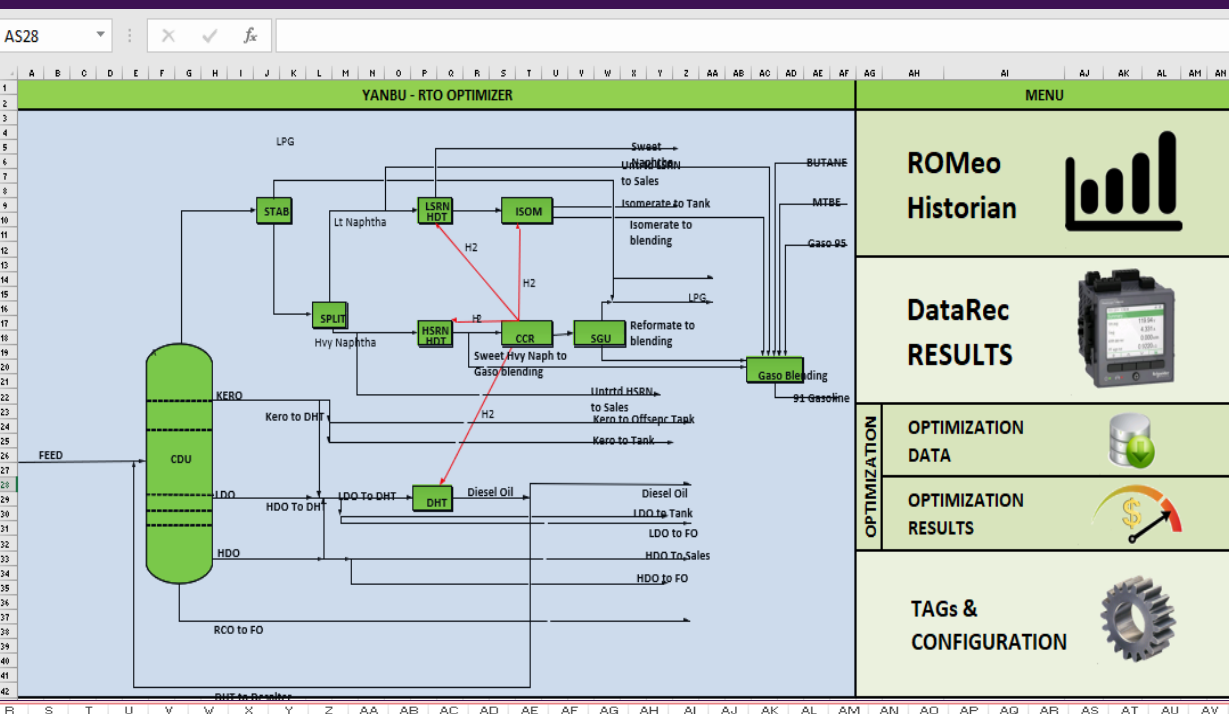

**MENU**

- ROMeo Historian
- DataRec RESULTS
- OPTIMIZATION DATA
- OPTIMIZATION RESULTS
- TAGs & CONFIGURATION

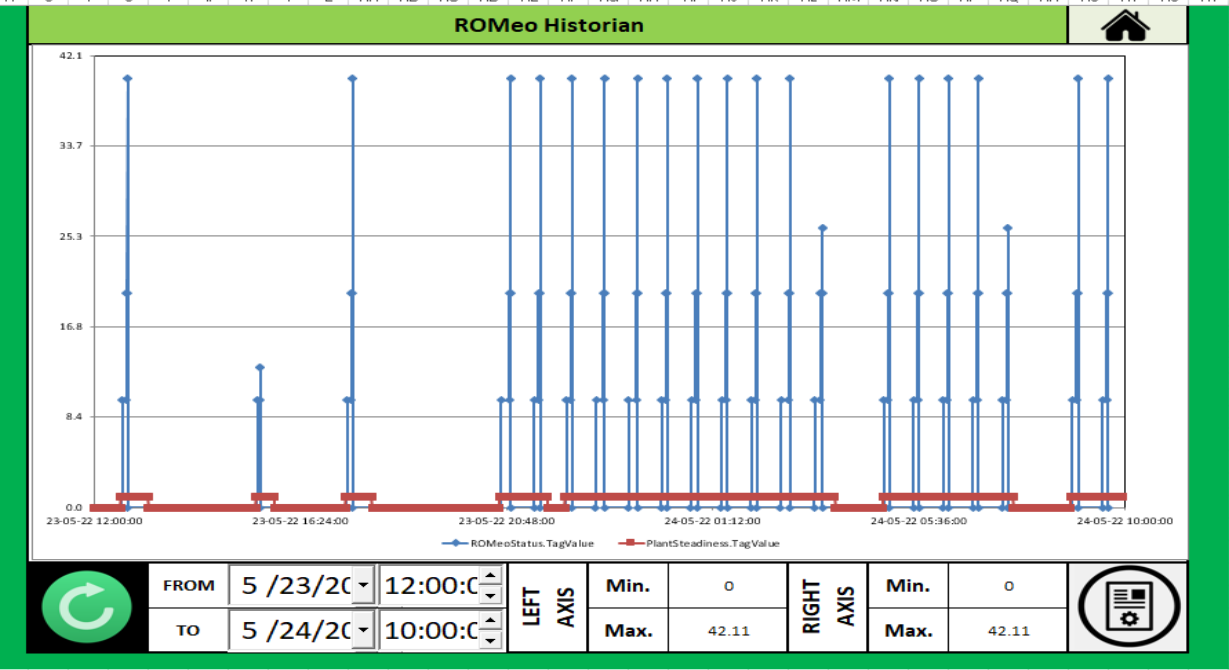

# Achievements & Innovations

## 1<sup>st</sup> Refinery-wide RTO in Middle East

- Hourly implementation frequency
- 10-minute computation time
- Rigorous process modelling throughout
- Model trained APC soft sensors
- RTO acts as “Soft Lab Update” for APC soft sensors
- Remote online development

## RTO System Actions

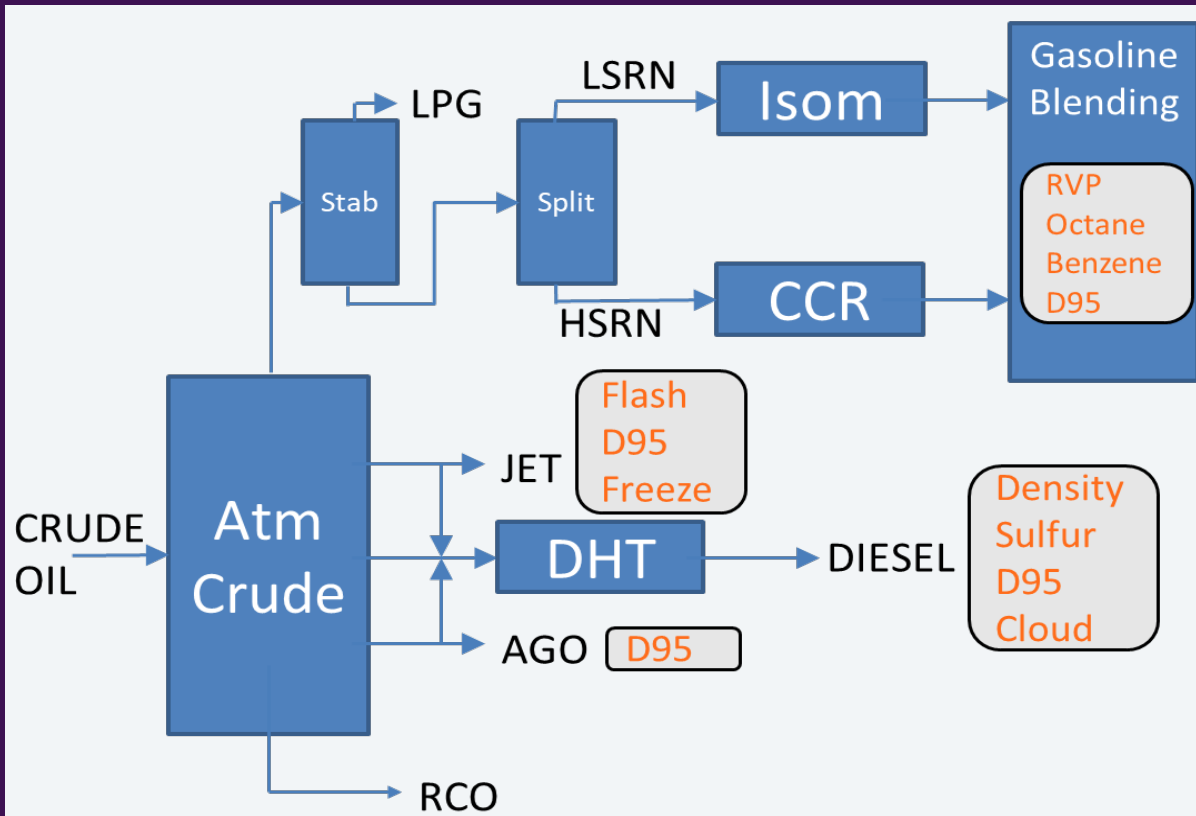

- Naphtha, Jet, Diesel and AGO product flows and characteristics continuously optimized subject to plan
- Stabilizer targets adjusted depending on gasoline product RVP
- Naphtha Splitter separation based on ISOM and CCR conditions and gasoline blending needs
- Conversion unit targets optimize gasoline blend components

# Optimizing Refinery Operations

aramco

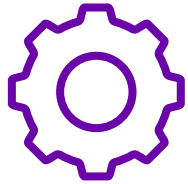

## Solution

- Deployed a **refinery-wide** optimization solution utilizing **AVEVA Process Optimization** software on a **PI System** infrastructure to provide real-time optimum operating targets for all key process parameters.



## Results

- **Project Payback: 3-6 Months**
- **On-Budget & On-Schedule Execution**
- High User Acceptance
- Reduced Operator Interventions
- Enhanced APC Utilization & Performance
- Enables Advanced Engineering Tools

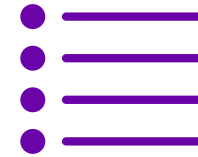

## Path Forward

- RTO results into business network **AVEVA PI System**
- Develop RTO KPI and Benchmarking displays utilizing **AVEVA PI AF & PI Vision**
- Extend refinery-wide process model into **Process Digital Twin**



## Doug Raven

### Engineering Specialist

- Saudi Aramco
- douglas.raven@aramco.com



## Project Team

### Saudi Aramco

- Khalid Alahmadi, Abdullah Bahamdan, Ammar Bakhurji, Othman Shamrani

### AVEVA

- Jesus Palacin, Longinos Velasco, Jaidev Parmar, Prasad Patgaonkar



# Questions?

Please wait for the microphone.  
State your name and company.



# Please remember to...

Navigate to this session in the mobile app to complete the survey.





# Thank you!



This presentation may include predictions, estimates, intentions, beliefs and other statements that are or may be construed as being forward-looking. While these forward-looking statements represent our current judgment on what the future holds, they are subject to risks and uncertainties that could result in actual outcomes differing materially from those projected in these statements. No statement contained herein constitutes a commitment by AVEVA to perform any particular action or to deliver any particular product or product features. Readers are cautioned not to place undue reliance on these forward-looking statements, which reflect our opinions only as of the date of this presentation.

The Company shall not be obliged to disclose any revision to these forward-looking statements to reflect events or circumstances occurring after the date on which they are made or to reflect the occurrence of future events.

 [linkedin.com/company/aveva](https://www.linkedin.com/company/aveva)

 [@avevagroup](https://twitter.com/avevagroup)

#### ABOUT AVEVA

AVEVA is a global leader in industrial software, sparking ingenuity to drive responsible use of the world's resources. The company's secure industrial cloud platform and applications enable businesses to harness the power of their information and improve collaboration with customers, suppliers and partners.

Over 20,000 enterprises in over 100 countries rely on AVEVA to help them deliver life's essentials: safe and reliable energy, food, medicines, infrastructure and more. By connecting people with trusted information and AI-enriched insights, AVEVA enables teams to engineer efficiently and optimize operations, driving growth and sustainability.

Named as one of the world's most innovative companies, AVEVA supports customers with open solutions and the expertise of more than 6,400 employees, 5,000 partners and 5,700 certified developers. With operations around the globe, we are headquartered in Cambridge, UK and listed on the London Stock Exchange's FTSE 100.

Learn more at [www.aveva.com](https://www.aveva.com)